

CHNAILE®

More reliable
solution to electric



Manufactured under supervision of
Naile Electric Co.,Ltd
Made in China

NLW1 Intelligent Circuit Breaker

⚡ ⚠ Warning

This product must be installed, connected, used and maintained by qualified personnel in accordance with the manual.

NLW1 Intelligent Circuit Breaker

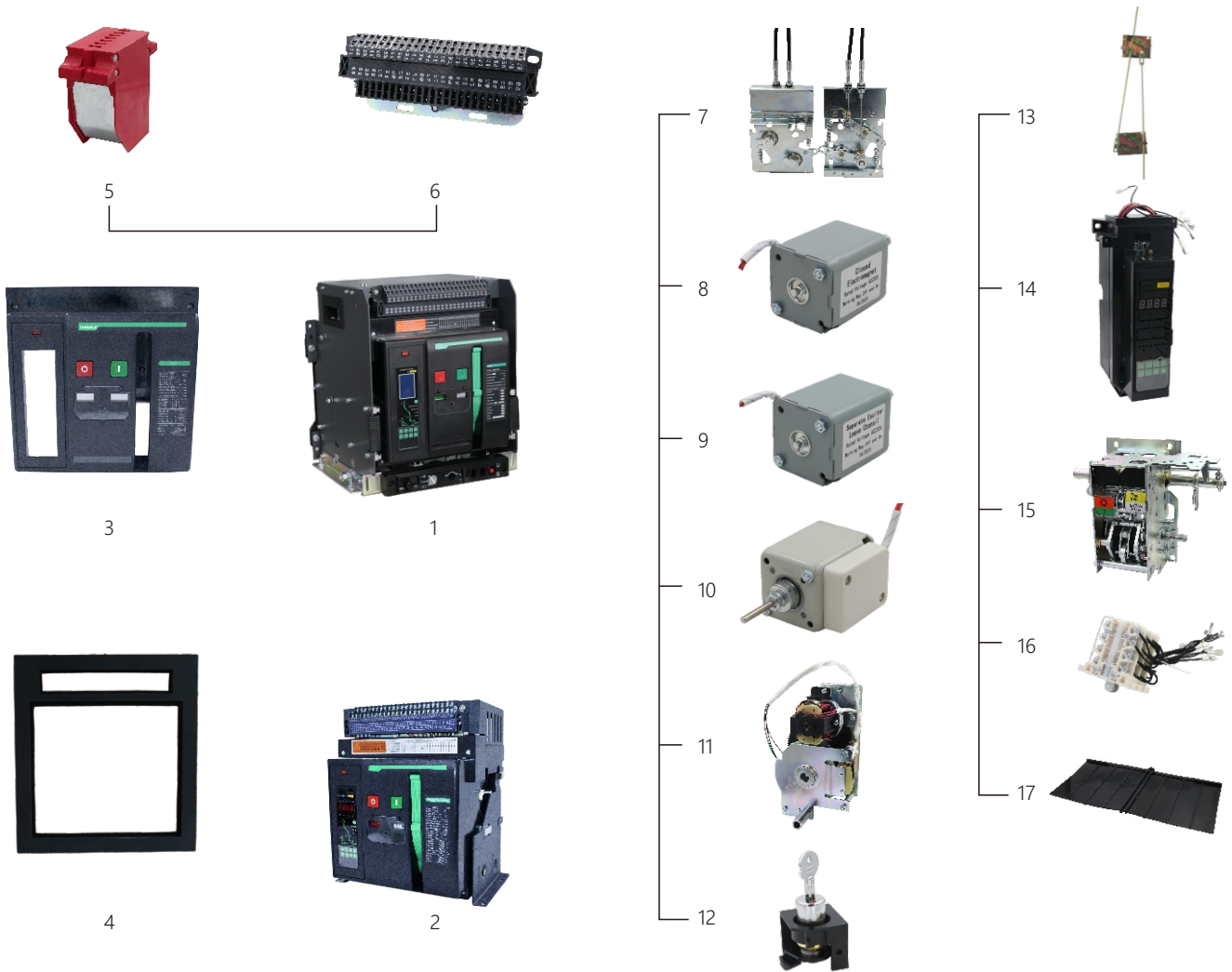

1	Drawer circuit breaker
2	Stationary circuit breaker
3	Front panel
4	Door frame
5	Arc chamber
6	Secondary circuit

7	Steel cable interlock
8	Closing electromagnet
9	Shunt release
10	Under voltage release
11	Electro drive energy storage mechanism
12	Lock

13	Lever interlock
14	Intelligent controller
15	Operating mechanism
16	Auxiliary switch
17	Phase partition

Application

NLW1 series intelligent circuit breaker is mainly suitable for a power distribution network with AC 50/60Hz, rated operating voltages of 400V, 690V and 800V, and rated current of 200A to 6300A, to distribute power, protect circuit and power devices against overload, under voltage, short circuit, and ground faults. The core part of the circuit breaker adopts intelligent controller with precise selective protection, which can avoid unnecessary power failure so as to improve the reliability, continuity and safety of the power supply system.

The circuit breaker can be widely used in the power distribution system of power stations, factories, mines and modern commercial buildings, especially in intelligent buildings. It is also often used in wind power generation, solar power generation and other green energy filed. The circuit breaker meets the IEC60947-2.

Type

- Installation mode: stationary type drawer type
- Operation mode: electric operation, manual operation
- Category use: type B
- Pole number: 3, 4
- Type of release device: intelligent controller, under voltage rekeage trigger and shunt release trigger.
- Intelligent type controller function
 - a. With overload long delay reverse time limit, short delay reverse time limit, short delay fixed time limit, instantaneous ac tion and other protection functions, can be set by the user, composed of the required protection characteristics;
 - b. Ground fault protection function; c. Overload alarm function; d. Test function;
 - e. Overload alarm function; g. Self-diagnostic function; h. MCR function;
 - i. Thermal simulation func tion; j. Contact loss indication;

Storage Environment

- The minimum temperature shall not be lower than -25°C, and the maximum temperature shall not exceed + 55°C;
- The relative temperature (+ 25°C) shall not exceed 95%;
- Products in the process of transportation, should be handled with special care, should not be inverted, should be tried to avoid violent collision.

Working Environment

- The ambient air temperature is -5°C ~ + 40°C, and the average value of 24h does not exceed + 35°C (except for special orders).
- The altitude of the installation site shall not exceed 2,000 m.
- The relative humidity of the air at the installation site shall not exceed 50% when the maximum temperature is +40°C; It can have higher relative humidity at lower temperature. The mean minimum temperature of the wettest

month shall not exceed +25°C, and the mean maximum relative humidity of the month shall not exceed 90%, taking into account the condensation occurring on the surface of the product due to temperature changes.

- The pollution grade is Grade 3.
- The main circuit of circuit breaker, the under voltage tripping coil and the primary coil of power transformer are installed as IV, while the other auxiliary circuit and control circuit are installed as III.
- The installation position shall be vertical, and the inclination in each direction shall not exceed 5°.



Technical Parameters

- Technical parameter of circuit breaker (see Table 1)

Table 1 Technical Parameters

Model		NLW1-1600	NLW1-2000	NLW1-3200	NLW1-4000	NLW1-6300
Rated current I_n (A)		200,400,630 800,1000 1250,1600	400,630,800 1000,1250 1600,2000	2000,2500 2900,3200,4000 (Increase capacity type)	3600,4000	4000,5000 6300
Neutral pole current rating I_n (A)		100% I_n	100% I_n	100% I_n	50% I_n	50% I_n
Rated operating voltage U_e (V)		AC400/690/800				
Pole number		3P, 4P				
Rated impact withstand voltage U_{imp} (kV)		AC12				
Nominal insulation voltage U_i (V)		AC1000				
Power frequency withstand voltage (V)		AC3500				
Rated limit short circuit breaking capacity I_{cu} (kA)	AC400V	65	80	100	100	120
	AC690V	50	50	65	65	-
Rated short circuit breaking capacity I_{cs} (kA)	AC400V	55	65	80	80	100
	AC690V	50	50	65	65	-
Rated short time withstand current $I_{cw}/1s$ (kA)	AC400V	55	50	65	65	100
	AC690V	50	50	65	65	-
Category of use		B				
Full break time (no additional delay)		≤30ms				
Closing time		≤70ms				
Electrical life (times) ≤3200 1h/20 >3200 1h/10	AC400V	6000	5000	3000	2000	1500
	AC690V	5000	4000	2000	1500	1000
Mechanical life (times) ≤2500 1h/20 >2500 1h/10	Maintenance-free	15000	10000	8000	5000	2000
	Have maintenance	20000	12000	10000	6000	2500
Mechanical life of the drawer holder (1h/20times)		1000	1000	1000	600	300

Into the line way	Up or down incoming line	
Arc distance(mm)	0	
Installation mode	Stationary type or Drawer type	
Mode of connection	Horizontal wiring or vertical wiring	Horizontal wiring

Note: One time of mechanical life of the drawer base refers to when the circuit breaker body is shaken from  "separated" to  "connected" and then to the  "separated" position in the drawer base.

- Maximum power loss of circuit breaker incoming and outgoing line (ambient temperature + 40°C)

Table 2 Power loss of incoming and outgoing lines of circuit breaker

Model	Frame current Inm (A)	Power loss(W)			
		3P Drawer type	4P Drawer type	3P Stationa type	4P Stationa type
NLW1- 1600	1600	230	306	136	182
NLW1-2000	2000	395	526	262	350
NLW1- 3200	3200	556	742	307	409
NLW1-4000	4000	660	880	332	450
NLW1-6300	6300	1429	1905	-	-

Note: Power consumption of the circuit breaker refers to the power consumption of the main circuit measured by the circuit breaker with the rated current at room temperature, excluding the power of other power loss accessories of the circuit breaker. This table data is only for reference and cannot be used as power consumption in actual use of the circuit breaker.

- Ambient temperature change Operating current drop capacity query

Table 3 Ambient temperature change Operating current drop capacity query

Model	Rated Current (A)	40°C	50°C	60°C	70°C
NLW1-1600	200	200	200	200	200
	400	400	400	400	400
	630	630	630	630	630
	800	800	800	800	800
	1000	1000	1000	1000	1000
	1250	1250	1250	1150	1150
	1600	1600	1500	1300	1300

NLW1-2000	400	400	400	400	400
	630	630	630	630	630
	800	800	800	800	800
	1000	1000	1000	1000	1000
	1250	1250	1250	1250	1250
	1600	1600	1600	1500	1300
	2000	2000	1800	1700	1600
NLW1-3200	2000	2000	2000	2000	2000
	2500	2500	2300	2200	2200
	2900	2900	2900	2800	2600
	3200	3200	3000	2800	2600
	4000	4000	3800	3600	3200
NLW1-4000	3600	3600	3500	3500	3400
	4000	4000	3800	3600	3400
NLW1-6300	4000	4000	4000	4000	4000
	5000	5000	5000	4800	4500
	6300	6300	5600	5200	5100

● Altitude capacity reduction coefficient

When the altitude exceeds 2000 meters, the insulation performance, cooling performance and pressure in the atmosphere will change, and its performance can be corrected by referring to Table 4

Table4 Coefficient of capacity reduction at altitude

Altitude(m)	2000	3000	4000	5000
Working current I_e	1	0.93	0.88	0.82
Short circuit breaking capacity I_{cu} I_{cs}	1	0.83	0.71	0.63
Short circuit tolerance I_{cw}	1	0.83	0.71	0.63
Rated impact withstand voltage U_{imp}	1	0.9	0.71	0.63
Power frequency withstand voltage	1	0.9	0.71	0.63
Rated insulation voltage U_i	1	0.83	0.71	0.63

When the ambient temperature is lower than 40°C, $I_e = I_n$. If the ambient temperature is higher than 40°C, the capacity of the circuit breaker must be reduced in strict accordance with the instructions during application. In this case, $I_e = I_n$ should be settled according to the current and temperature.

- The recommendation for installing of busbar

Table 5 Recommendation for installing of busbar

Rated current (A)	External copper busbar (width*thickness) mm	Required busbar qty per pole	Cross-sectional area (mm ²)
200	20×5	1	100
400	40×5	1	200
630	40×5	2	400
800	50×5	2	500
1000	60×5	2	600
1250	80×5	2	800
1600	100×5	2	1000
2000	100×5	3	1500
2500	100×5	4	2000
2900	100×10	3	3000
3200	100×10	4	4000
3600	100×10	5	5000
4000	100×10	5	5000
5000	100×10	6	6000
6300	100×10	8	8000

Note: The specification in the table is that the circuit breaker used in ambient environment of 40°C and installed open. The material of busbar is T2 bare copper. The specification of the external copper busbar can be changed according to the actual use situation, but it should meet the cross-sectional area requirements corresponding to different currents in the table.

- Protection performance of the intelligent controller

The over current protection characteristic curve of the intelligent controller is shown in Figure 1

a. The setting range I / I_n and accuracy of the intelligent controller

Protection type	Long time delay		Short time delay		instantaneous		Ground protection	
	I_R	Accuracy	I_{sd}	Accuracy	I_i	Accuracy	I_g	Accuracy
NLW1- 1600	(0.4~1) I_n	±10%	(0.4~15) I_n	±10%	1 I_n ~50kA +OFF	±15%	(0.2~1) I_n	±10%
NLW1-2000					1 I_n ~50kA +OFF			
NLW1- 3200/4000					1 I_n ~75kA +OFF			
NLW1-6300					1 I_n ~100kA +OFF			

b. Long time delay over current protection reverse time limit action characteristics

For the long time delay over current protection, the reverse time limit curve conforms to the characteristic curve of I² TL = (1.5 Ir 1) 2 tL. Where I is the actual action current; TL is the actual action time with a long time delay; and tL is the setting time for a long time delay of 1.5 IR.

Current multiple	Action time						
1.05I _R	No action within 2 h						
1.3I _R	<1h action						
1.5I _R	Setting time(s)	15	30	60	120	240	480
2.0I _R	Actuation time(s)	8.4	16.9	33.7	67.5	135	270

c. Short time delay over current protection action characteristics

Current	Action time					
I ≥ I _{sd} , I ≤ 8I _R	Inverse time limit	I ² T _s = (8IR) ² t _s				
I ≥ I _{sd} , I > 8I _R	Fixed time limit	Setting time (s)	0.1	0.2	0.3	0.4
		Action time(s)	0.06	0.14	0.23	0.35
Note: a) action time tolerance ± 15%. b) I is the actual action current; t _s is the set time for short time delay; and T _s is the actual action time.						

d. Short circuit instantaneous protection action characteristics

The instantaneous protection function prevents the load from short circuit in the distribution system. This kind of fault usually happens between phases so the short circuit current is relatively big, which needs to be disconnected quickly. This protection is executed based on the true effective value of the current. When I ≤ 0.85I_i, I > 1.15I_i (I is actual short circuit current).

e. The protection characteristics and curve of grounding fault (Figure 2)

There are two kinds of ground fault protection: one is to detect the current of neutral point, when the current of three-phase is in balance, the neutral point current is zero. When the current of three-phase is in imbalance, the current of neutral point exceeds the set value, the intelligent controller alarms, the circuit breaker is disconnected or constantly open according to the instruction after the fixed delay time. The other is to detect the current of the grounding wire, when the current exceeds the set value, the intelligent controller alarms, make the circuit breaker be disconnected or constantly open according to the instruction after the fixed delay time. The grounding fault protection characteristics is fixed time limit.

Action current Set 6Point I _g	(0.2~1)I _n +OFF
Action characteristic	≤0.8I _g failure to actuate
	≥1.1I _g deferred action
Setting time (s)	(0.2~1)I _n +OFF(OFF That only the alarm is not removed)

f. Self-diagnostic function

The intelligent controller can diagnose its own fault when failure happens to the computer. It can display "E" (means error) or alarm, and restart computer at the same time. The circuit breaker can be disconnected when necessary. When the local ambient temperature reaches 80°C or the temperature in the casing exceeds 80°C due to the heat of the contact, an alarm can be issued, and the circuit breaker can be switched off at a smaller current (when the user needs).

Figure 1 Over current protection characteristic curve of the intelligent controller

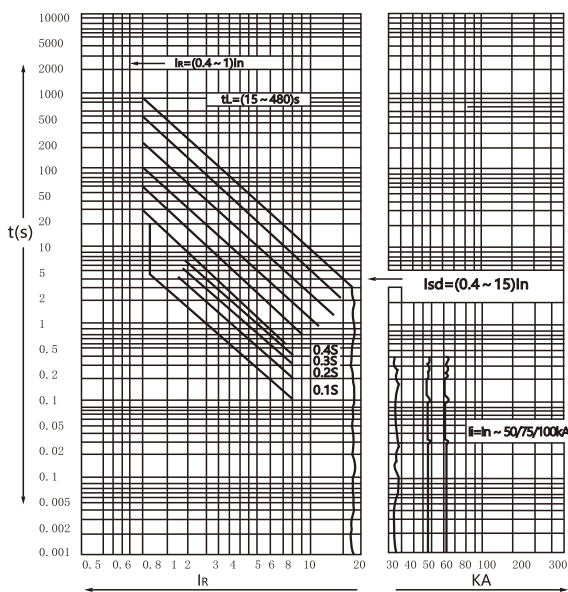
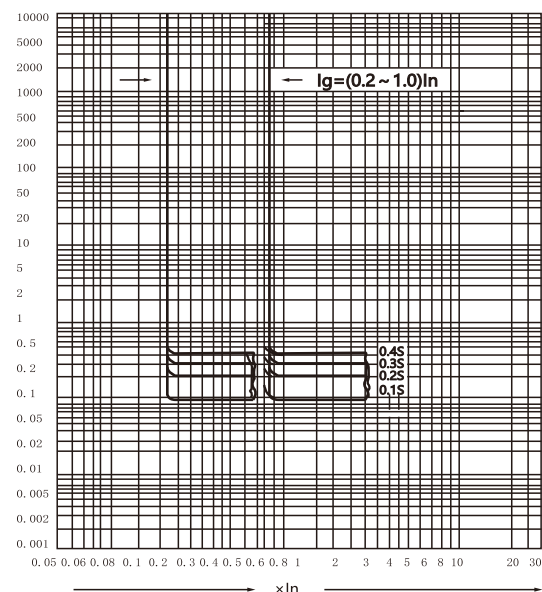
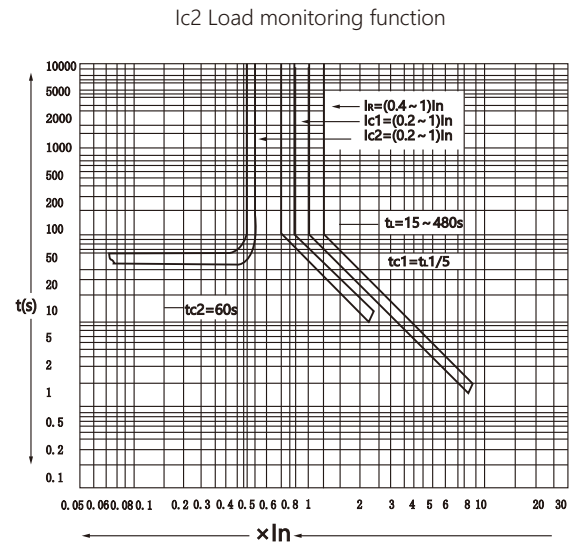
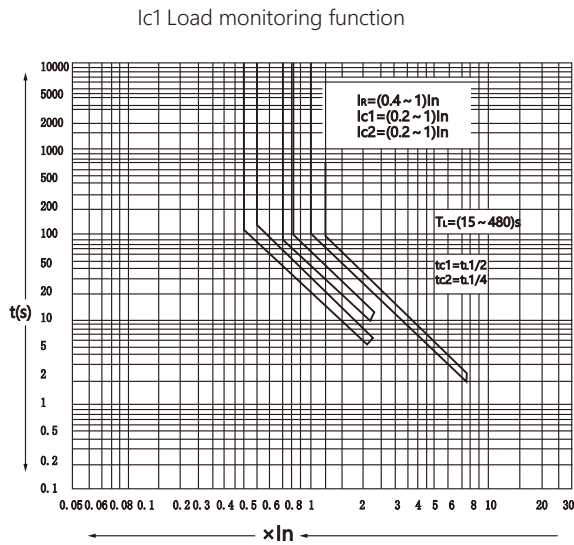

Figure 2 Ground fault protection characteristic curve



g. Load monitoring function

Set two set values I_{c1} and I_{c2} , setting range of both are $(0.2 \sim 1) I_n$. The delay feature of I_{c1} is the reverse time limit characteristic, its delay setting value is $1/2$ of the long delay setting value. There are two kinds of delay characteristics for I_{c2} : one is the reverse time limit characteristics, its value of time setting is $1/4$ of the long time delay setting value; The other is the fixed time limit characteristic, its delay time is 60s. The first delay function is used to switch off the least important load when the current approaches the set overload value. The latter delay function is used to delay switching off unimportant load to decrease the current in order to maintain the power supply for main circuit and important load circuits when the current exceeds the I_{c1} value. When the current drops to I_{c2} , a command is issued after a delay to reconnect the lower circuit that has been cut off restore the power supply to the entire system. The load monitoring features are shown in the following figure.



h. Display function of the controller

The controller shall display its operating current during operation (i.e., functioning as an ammeter). In the event of a fault, it shall display the zone specified by its protection characteristics, and latch the fault display and fault current after the circuit is tripped. During setting, it shall display the current, time and zone type of the set zone. For time-delayed operation, the indicator lamp flashes during the operation process, and changes from flashing to steady illumination after the circuit breaker trips. During testing, it shall display the test current, time-delay test indication and the tripped zone under test.

i. DO signal and alarm function

The controller provides 8 channels of DO (Digital Output) signals for controller indication or audible-visual alarm. The corresponding functions are: overload pre-alarm signal, short-circuit trip signal (short-time delay and instantaneous), long-time delay trip signal, earth fault trip or alarm signal, load monitoring 1 signal, load monitoring 2 signal, self-diagnostic alarm signal, and fault trip signal (OCR).

j. MCR and over ultimate trip protection

MCR and Overlimit Trip functions are high-speed instantaneous protections. The fault current signal directly issues an operation command via a hardware comparison circuit. MCR protection is only active during the circuit breaker closing instant (within approximately 100 ms), whereas Overlimit Trip protection remains active continuously during operation. MCR protection safeguards the ultimate making capacity of the circuit breaker, preventing currents exceeding the breaker's making capacity at the moment of closing when a short-circuit fault already exists on the grid before closing; the controller trips the circuit breaker instantaneously. Overlimit Trip protection safeguards the ultimate carrying capacity of the circuit breaker, preventing damage caused by currents exceeding its ultimate carrying capacity.

k. Thermal memory function

Following an overload or short-time delay trip, the controller features a thermal effect simulating bimetal characteristics. The overload thermal energy is fully released within 30 minutes, and the short-time delay energy within 15 minutes. If an overload or short-time delay fault reoccurs during this period, the tripping time will be shortened. When the controller is de-energized, the accumulated energy is automatically reset.

l. Regional-selective linkage

In the same power circuit, two or more circuit breakers with a hierarchical relationship can implement Zone Selective Interlocking (ZSI), including short-circuit interlocking and earth fault interlocking. There are two possible scenarios depending on the fault location.

When a short-circuit or earth fault occurs on the outgoing side of the downstream circuit breakers (CB#2~CB#4) (e.g., Position 2), the downstream breaker trips instantaneously and sends a zone interlocking signal to the upstream breaker. The upstream breaker (CB#1) receives the zone interlocking signal and operates with a time delay according to the short-circuit or earth fault protection settings. If the fault current is cleared during the upstream delay period, the protection resets and the upstream breaker does not operate. If the fault current persists after the downstream breaker trips, the upstream breaker operates according to the short-circuit or earth fault protection settings to isolate the faulty circuit.

When a short-circuit or earth fault occurs between the upstream breaker (CB#1) and downstream breakers (CB#2~CB#4) (e.g., Position 1), the upstream breaker does not receive a zone interlocking signal and therefore trips instantaneously to quickly isolate the faulty circuit.

I/O port configuration requirements:

The upstream circuit breaker shall have at least one DI configured for zone interlocking detection;

The downstream circuit breaker shall have at least one DO configured for zone interlocking signal output.

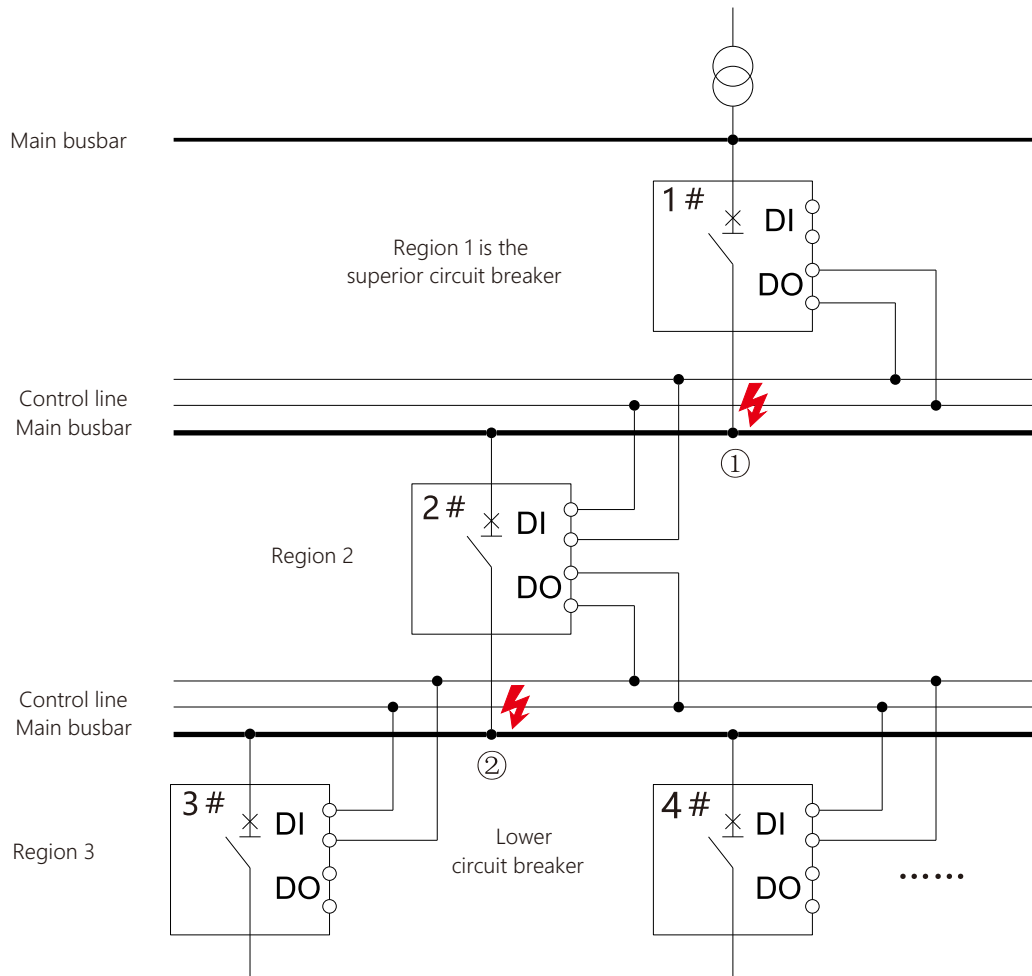

- Preset value of the intelligent controller

Table 6 Preset value of the intelligent controller

Controller type	Long delay		Short delay		Instantaneous	Ground protection		Load monitoring	
	I_R	t_L	I_{sd}	t_L	I_i	I_g	t_G	I_{c1}	I_{c2}
NLW1- M	$1I_n$	60s	$8I_R$	0.2s	$12I_R$	$0.8I_R$	OFF	$1I_n$	
NLW1-2M/ 3M	$1I_n$	60s	$8I_R$	0.2s	$12I_R$	$0.8I_R$	OFF	$1I_n$	

Structure Overview

Stationary type circuit breaker is mainly composed of contact system, intelligent controller, manual operation mechanism, electric operation mechanism and fixed installation board; Drawer type circuit breaker is mainly composed of contact system, intelligent controller, manual operation mechanism, electric operation mechanism and drawer holder;

The contact system is closed in the insulating floor, and each phase contact is separated by the insulation board to form a small chamber, while the intelligent controller, the manual operation mechanism and the electric operation mechanism are arranged in front of it, forming independent units. If one of the units is broken, the whole unit can be removed and replaced with a new one.

The circuit breaker consists of a body and a fixed bracket, and becomes a stationa



Drawer type circuit breaker is composed of the circuit breaker body and the drawer holder. The guide rail in the drawer holder can be pulled in and out, and the main loop is connected through the bus on the circuit breaker body and the bridge plug on the drawer holder.

Drawer type Circuit breaker has three working positions: "connected" position, "test" position, "seperated" position, position change through the rotation in or out of the handle. The indication of the three locations is shown by the pointer on the drawer seat beam. When in the "connected" position, the main loop and the secondary loop are connected. When in the "test" position, the main loop is disconnected and separated by an insulation partition, only the secondary loop is connected, some necessary action tests can be carried out, when in the "seperated" position, the main and secondary circuits are all disconnected. And the Drawer type circuit breaker has a mechanical interlocking device, the circuit breaker can only be switched on in the "connected" position or the "test" position, and the circuit breaker cannot be switched on in the middle position between position of "connected" and the "test".

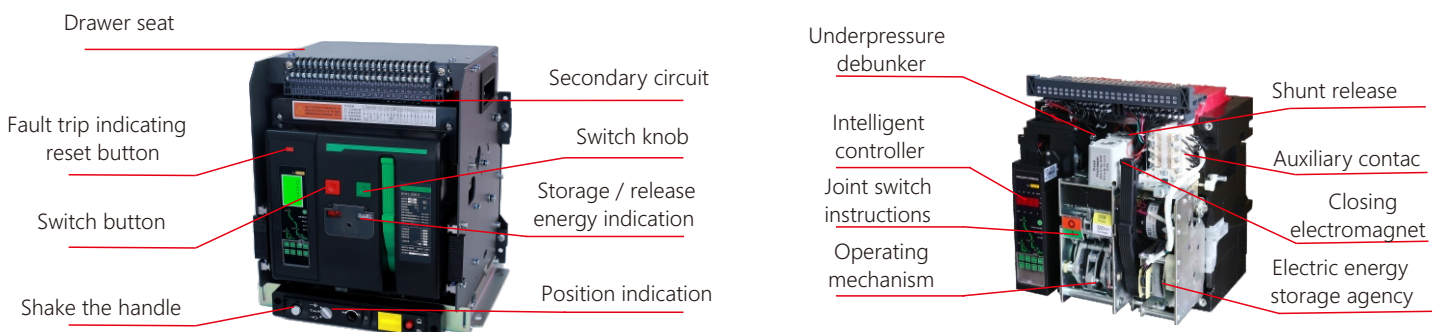

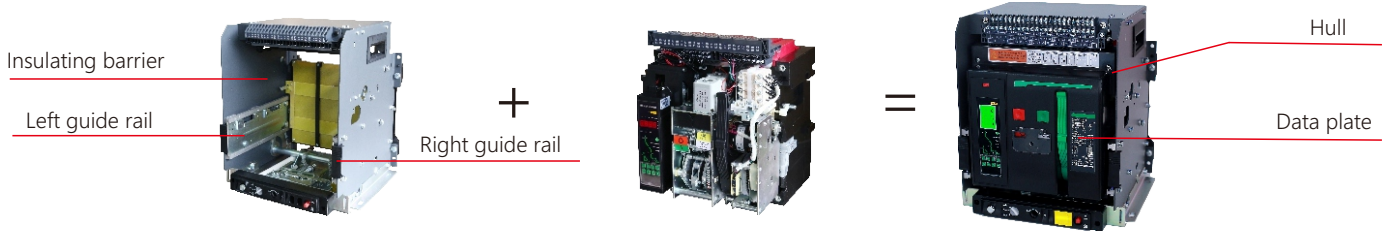

The circuit breaker consists of two parts: the body and the drawer holder, and the body is inserted into the drawer holder.

- Intelligent controller mechanical reset button



Normal operating state



The intelligent controller is in protection state, and the circuit breaker is open at this time. After clearing the line fault, press this button to enable normal closing of the circuit breaker.

- Operating state of the operating mechanism

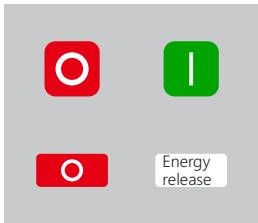

Circuit breaker is disconnected and no energy storage

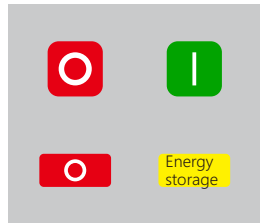

Circuit breaker is disconnected and the energy storage state has been completed

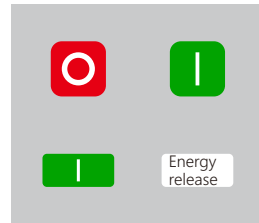

Circuit breaker switched on and no energy storage

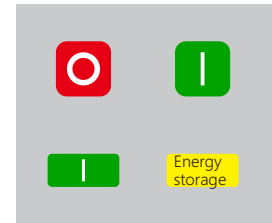

Circuit breaker switched on and the energy storage state has been completed

- Drawer type circuit breaker (Only the Drawer type circuit breakers have this function)



Connected position: Both the main circuit and the auxiliary circuit are connected.



Test position: Main circuit disconnected, auxiliary circuit connected.



Disconnected position: Both main circuit and auxiliary circuit are disconnected.

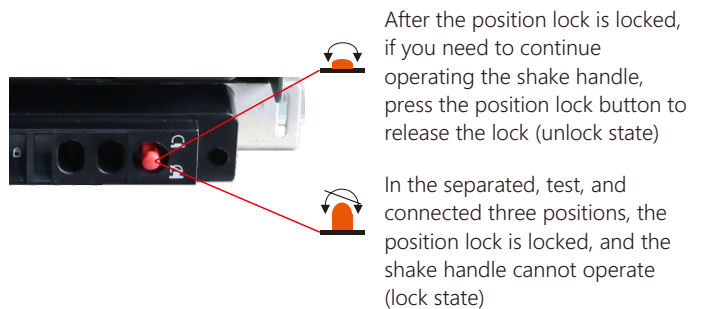

After the position lock is locked, if you need to continue operating the shake handle, press the position lock button to release the lock (unlock state)

In the separated, test, and connected three positions, the position lock is locked, and the shake handle cannot operate (lock state)

Three position lock of the drawer holder: lock the circuit breaker body in the drawer holder: "separated", "test" and "connected".

Control Loop

- Secondary Circuit Wiring Diagram for NLW1-2000~6300 with Type M Intelligent Controller

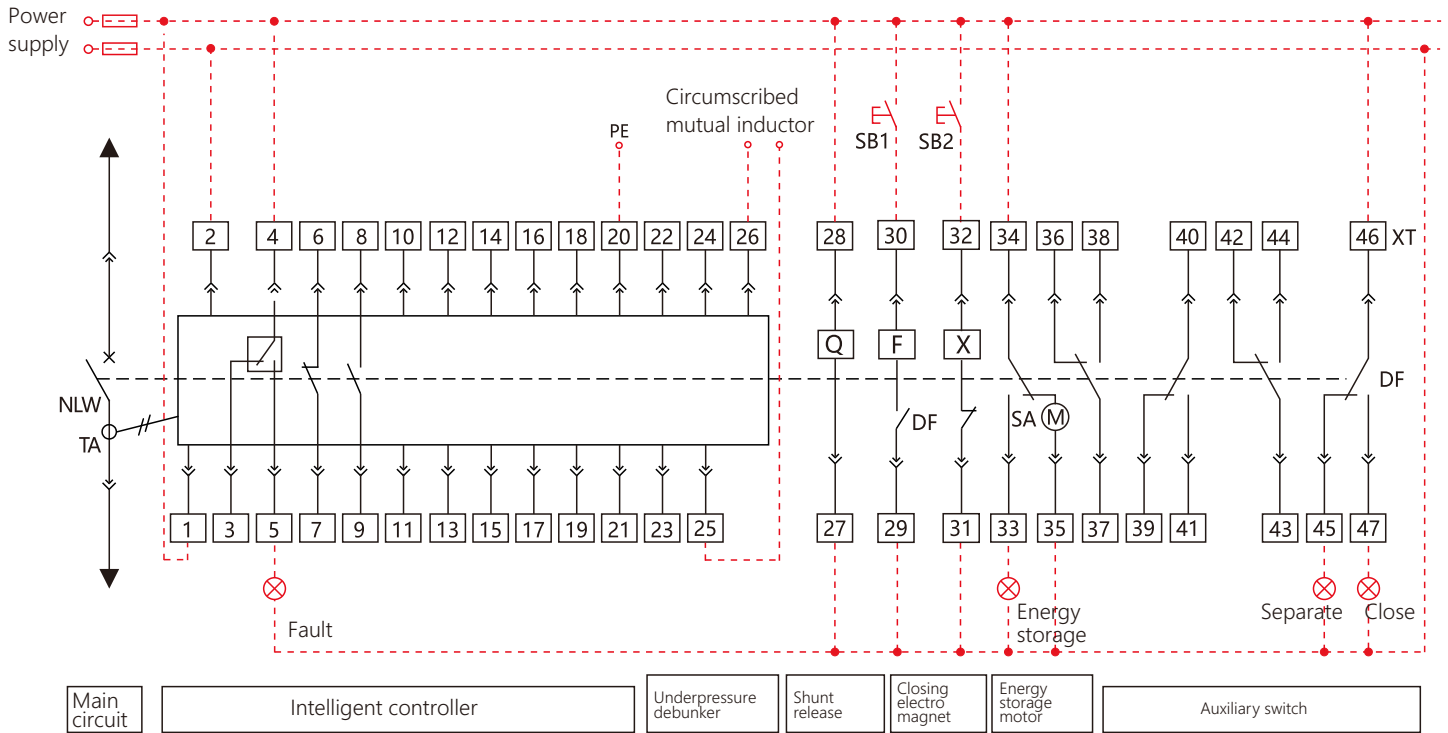

Symbol definition and terminal function in the wiring diagram (the red dotted line is wired by the user himself, and the control loop is protected by a fuse)

Note: The under voltage tripping button can also be connected to the normally closed button as an emergency switch button in emergency cases.

Symbol	Paraphrase	Remarks
Q	Under voltage release	Optional attachment
F	Shunt release	
X	Closing electromagnet	
DF	Auxiliary switch	
SA	Motor micro-dynamic switch	

Symbol	Paraphrase	Remarks
M	Electric motor	
XT	Terminal connector	
⊗	Signal lamp	User self-provided
SB1	Manual switch button	User self-provided
SB2	Manual closing button	User self-provided

Terminal number	Terminal function description	Remarks
1,2	Auxilia power supply input: AC230V, AC400V, DC220V, and DC110V	Type M default configuration
3,4,5	Fault trip contact output (4 # is the public end), contact capacity: AC250V, 3A	
6,7	Breaker state auxiliary contact output (normally closed), contact capacity: AC250V, 3A	
8,9	Breaker state auxiliary contact output (often open), contact capacity: AC250V, 3A	
20	Dependency (PE)	
25,26	a: Connect neutral wire transformer for 3P + N; b: Connect leakage transformer during leakage protection (alternative)	Optional attachment
27,28	Unde oltage tripping device (directly connected to the autonomous circuit power supply to improve the reliability and security of power supply)	Optional attachment
29,30	Shunt release	
31,32	Closing electromagnet	
33,34,35	Motor (35 can be directly connected to the power supply automatic pre-storage, or the power supply manual pre-storage)	
36~47	Auxiliary switch Terminal terminal (default four ad conversion)	

• Secondary-circuit wiring diagram of NLW1-1600 with M-type intelligent controller

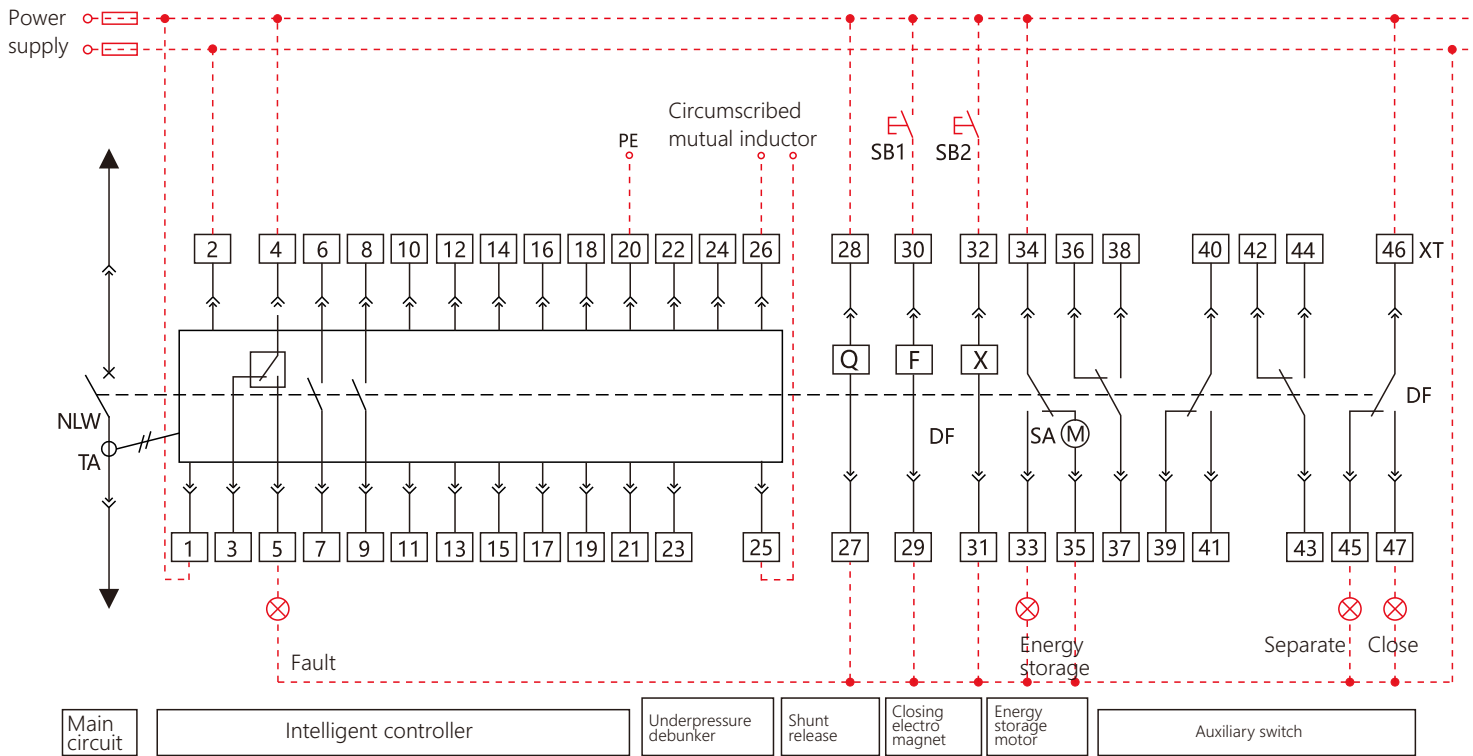

The red dotted line in the wiring diagram is wired by the user himself, and the control circuit should be protected by the fuse.

Note: Under voltage release can also be connected frequently closed button, as an emergency switch button in emergency cases.

NLW1-2000~6300 Auxiliary switch (DF) type

1. 4 conversion contacts (default configuration)

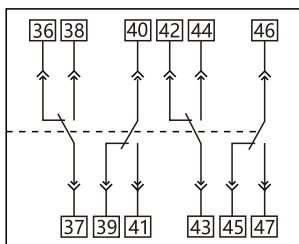

2. 5 sets of transition contacts (Type M)

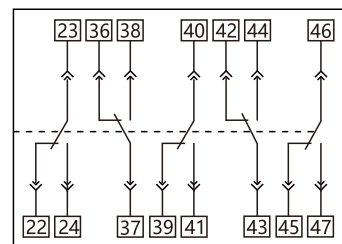

3. 4NO+4NC (M type)

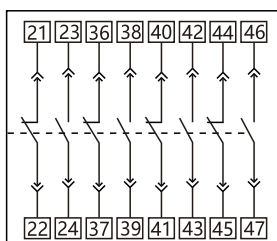

4. 6NO+6NC (M type)

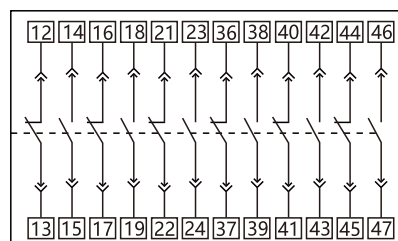

Symbol	Paraphrase	Remarks	Symbol	Paraphrase	Remarks
Q	Under voltage release	Optional attachment	M	Electric motor	
F	Shunt release		XT	Terminal connector	
X	Closing electromagnet		⊗	Signal lamp	User self-provided
DF	Auxiliary switch		SB1	Manual switch button	User self-provided
SA	Motor micro-dynamic switch		SB2	Manual closing button	User self-provided

Terminal number	Terminal function description	Remarks
1,2	Auxiliary power supply input: AC230V, AC400V, DC220V, and DC110V	Type M default configuration 2H / 3H communication type configuration
3,4,5	Fault trip contact output (4 # is the public end), contact capacity: AC250V, 3A	
6,7	Breaker state auxiliary contact output (often open), contact capacity: AC250V, 3A	
8,9	Breaker state auxiliary contact output (often open), contact capacity: AC250V, 3A	
20	Protection area (PE)	2H / 3H communication type configuration
10,11	Rs485 communication interface lead, 10 to A, 11 to B (default Modbus)	
12,19	Relay contact output: 12 and 13 are DO 1; 14 and 15 are DO 2; 16,17 D 3 for remote switch DO contacts; 18 and 19 DO 4 for remote switch contacts	
21,22,23,24	Voltage measurement input: 21 N, 22 A, 23 B, 24 C	Optional attachment
25,26	a: Connect neutral wire transformer for 3P + N; b: Connect leakage transformer for leakage protection (alternative)	
27,28	Under voltage release (Direct connected to autonomous loop power supply to improve the reliability and security of power supply)	Optional attachment
29,30	Shunt release	
31,32	Closing electromagnet	
33,34,35	Electric motor(35 can be directly connected to the power supply automatic pre-storage, or can connect the power supply manual pre-storage)	
36~47	Auxiliary switch Terminal terminal (default four ad conversion)	

Overall Dimension

- NLW1-1600 Stationary Type Circuit Breaker - Profile & Installation Dimensions (mm).

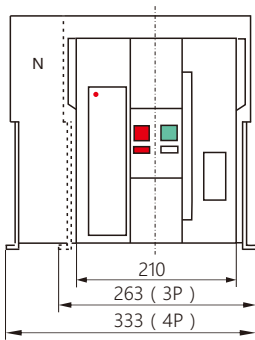

In	a
200 ~ 630A	8
800 ~ 1000A	10
1250 ~ 1600A	18

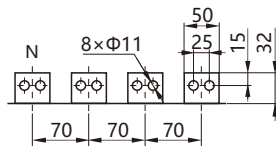

Horizontal Short Busbar (Default Configuration)

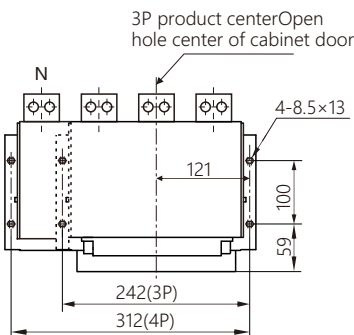
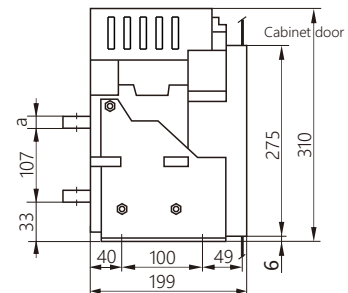

Installation size

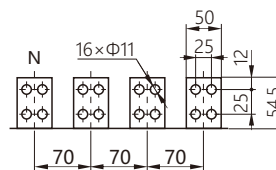

Horizontal Long Busbar (Customized)

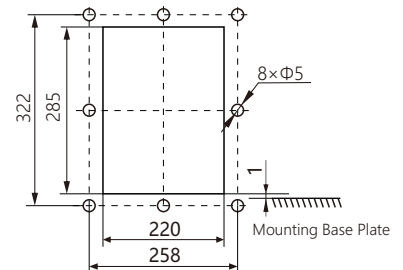

Cutout size of cabinet door

● NLW1-1600 Draw-out Circuit Breaker - Overall & Mounting Dimensions (mm).

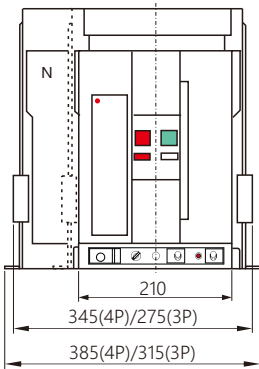

In	a
200 ~ 630A	8
800 ~ 1000A	10
1250 ~ 1600A	18

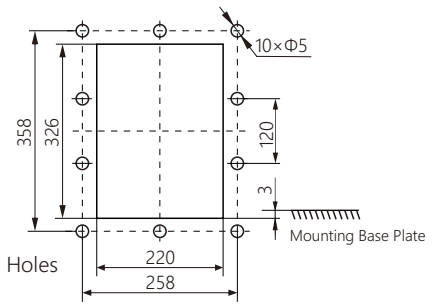
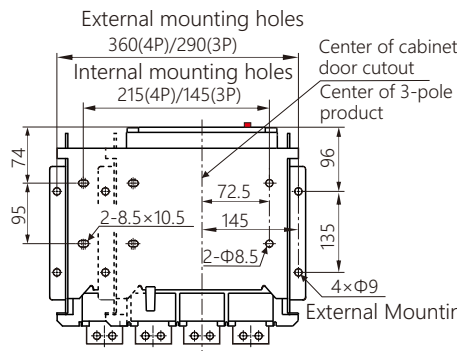
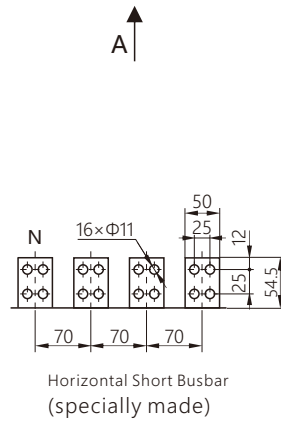
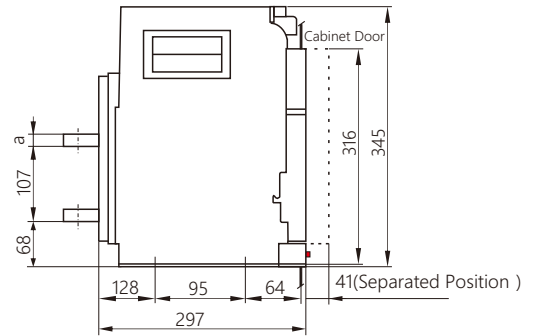
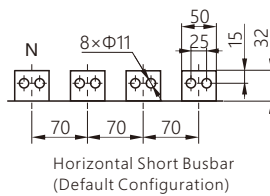

A-direction mounting dimensions

Cabinet Door Cutout Dimensions

● NLW1-2000 Stationary Type Circuit Breaker - Profile & Installation Dimensions (mm).

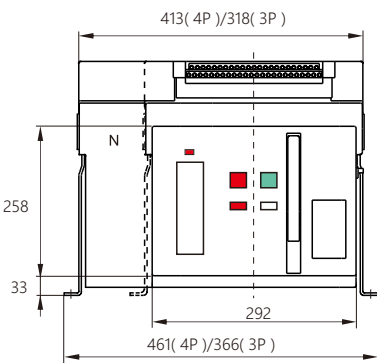

In	a
400 ~ 800A	10
1000 ~ 1600A	15
2000A	20

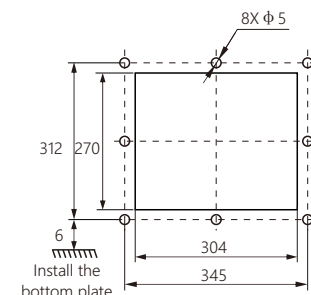
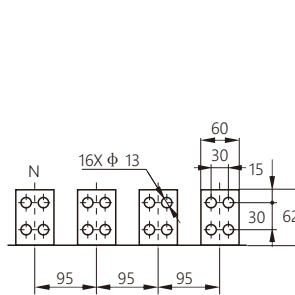
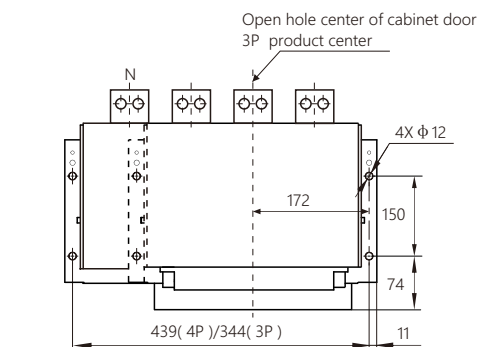
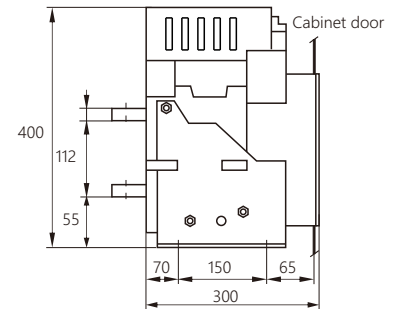
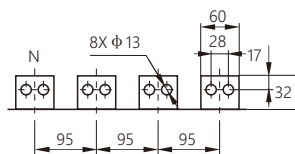

Installation size

Horizontal Short Busbar (specially made)

Cutout size of cabinet door

● NLW1-3200 Stationary Type Circuit Breaker - Profile & Installation Dimensions (mm).

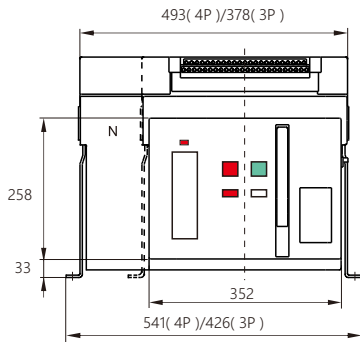

In	a
2000~2500A	20
3200A	30

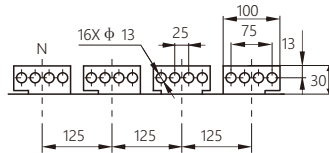

Horizontal Short Busbar (Default Configuration)

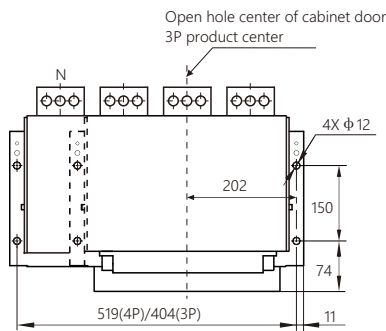
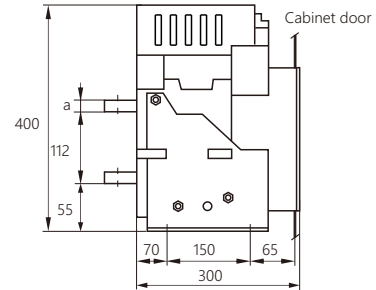

A Installation size

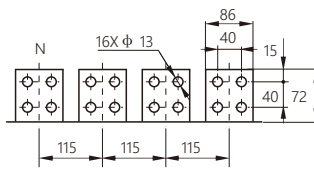

Horizontal long busbar (specially made)

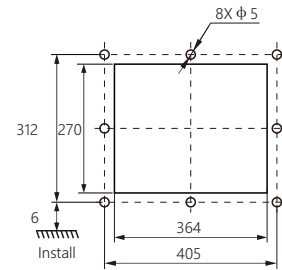

Cutout size of cabinet door

● NLW1-2000 Draw-out Circuit Breaker - Overall & Mounting Dimensions (mm).

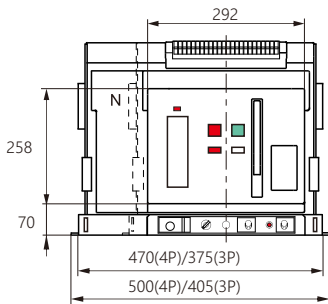

In	a
400~800A	10
1000~1600A	15
2000A	20

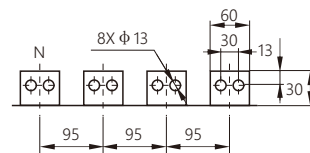

Horizontal Short Busbar (Default Configuration)

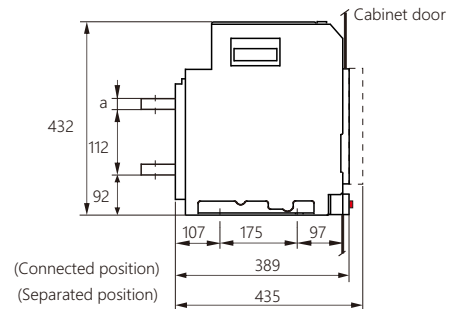

(Connected position)
(Separated position)

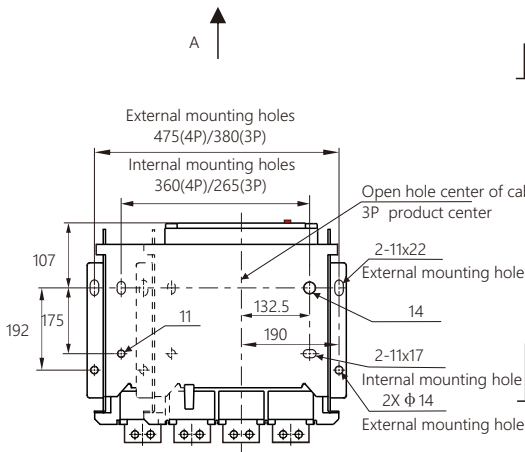

A Installation size

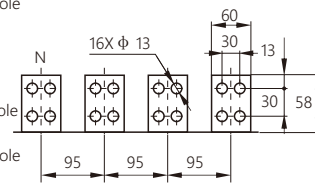

Horizontal long busbar (specially made)

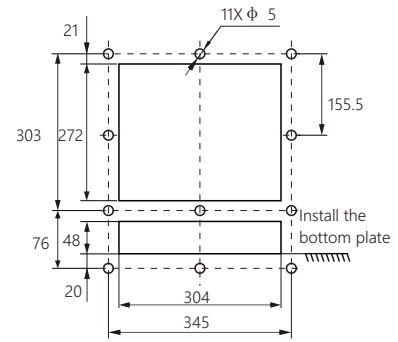

Cutout size of cabinet door

● NLW1-3200 Draw-out Circuit Breaker - Overall & Mounting Dimensions (mm).

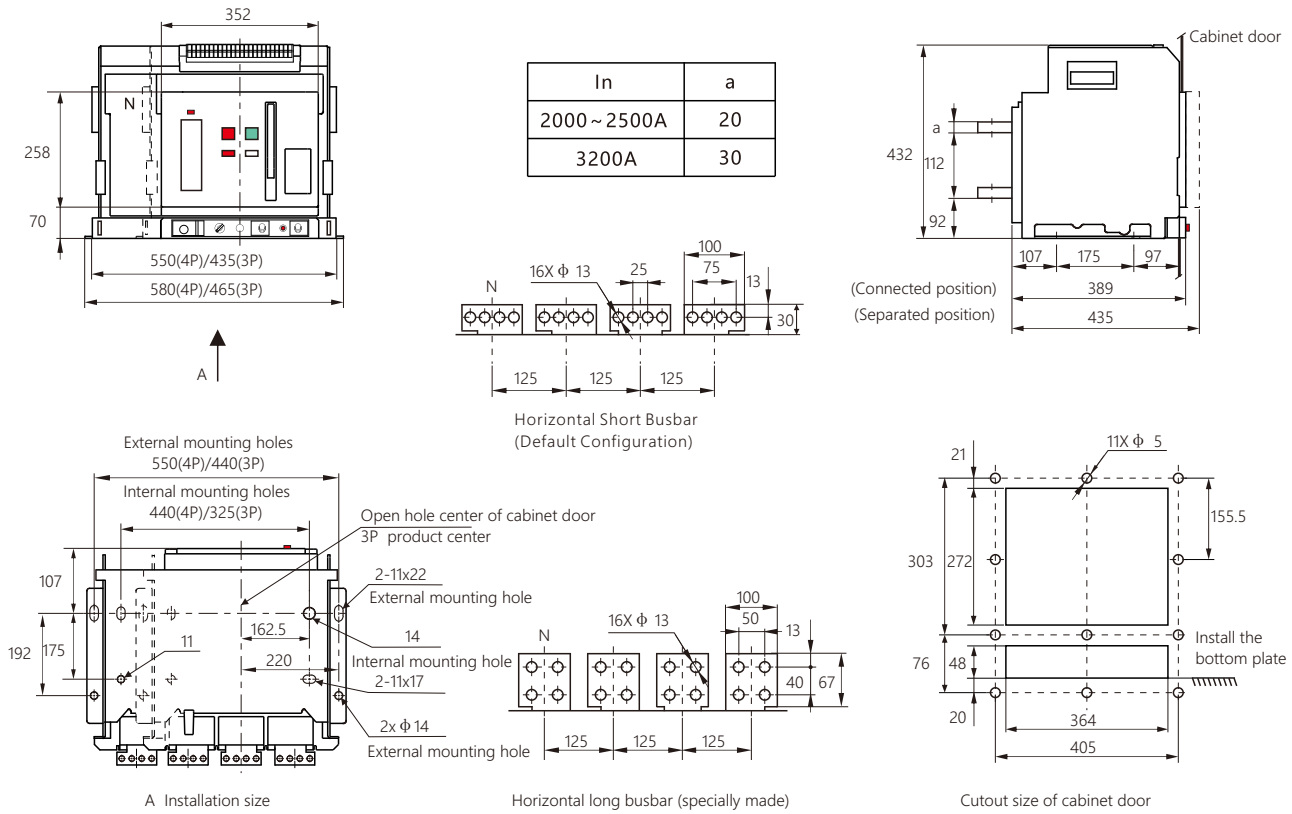

● NLW1-4000/3P Stationary Type Circuit Breaker - Profile & Installation Dimensions (mm).

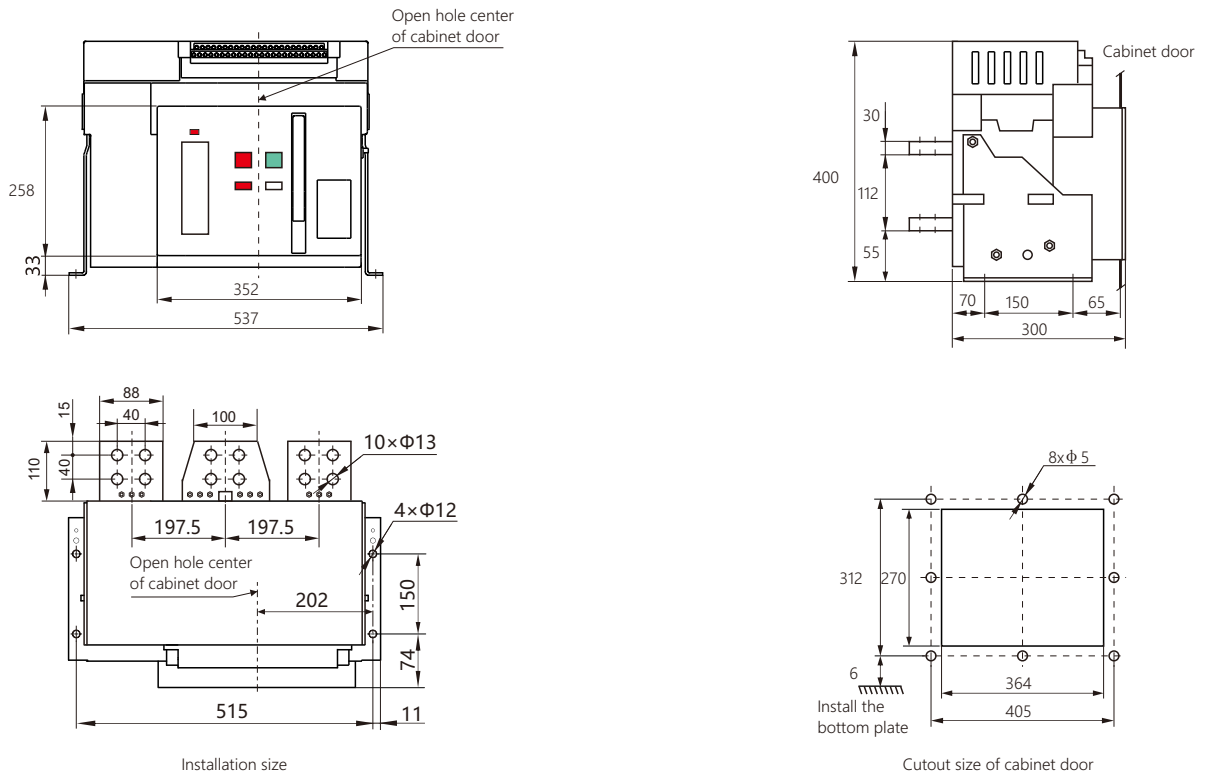

● NLW1-4000/3P Draw-out Circuit Breaker - Overall & Mounting Dimensions (mm).

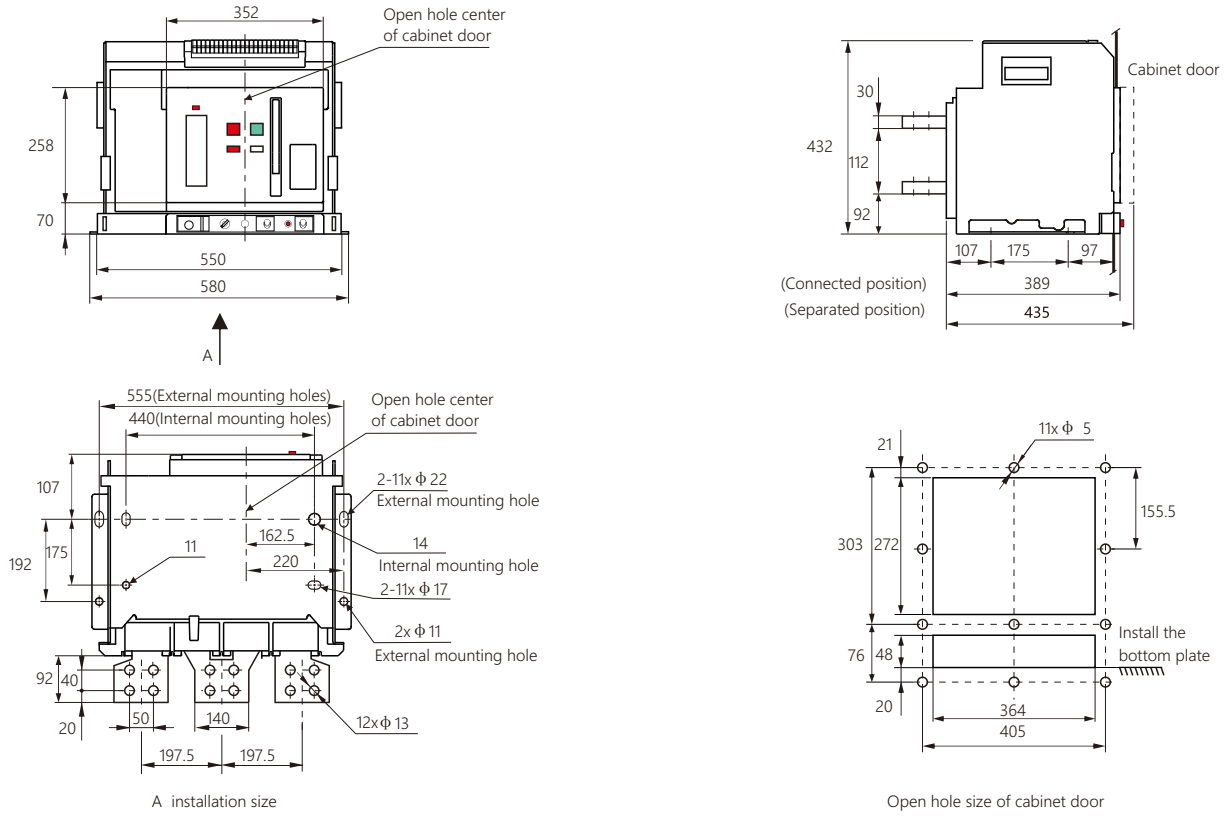

● NLW1-4000/4P Stationary Type Circuit Breaker - Profile & Installation Dimensions (mm).

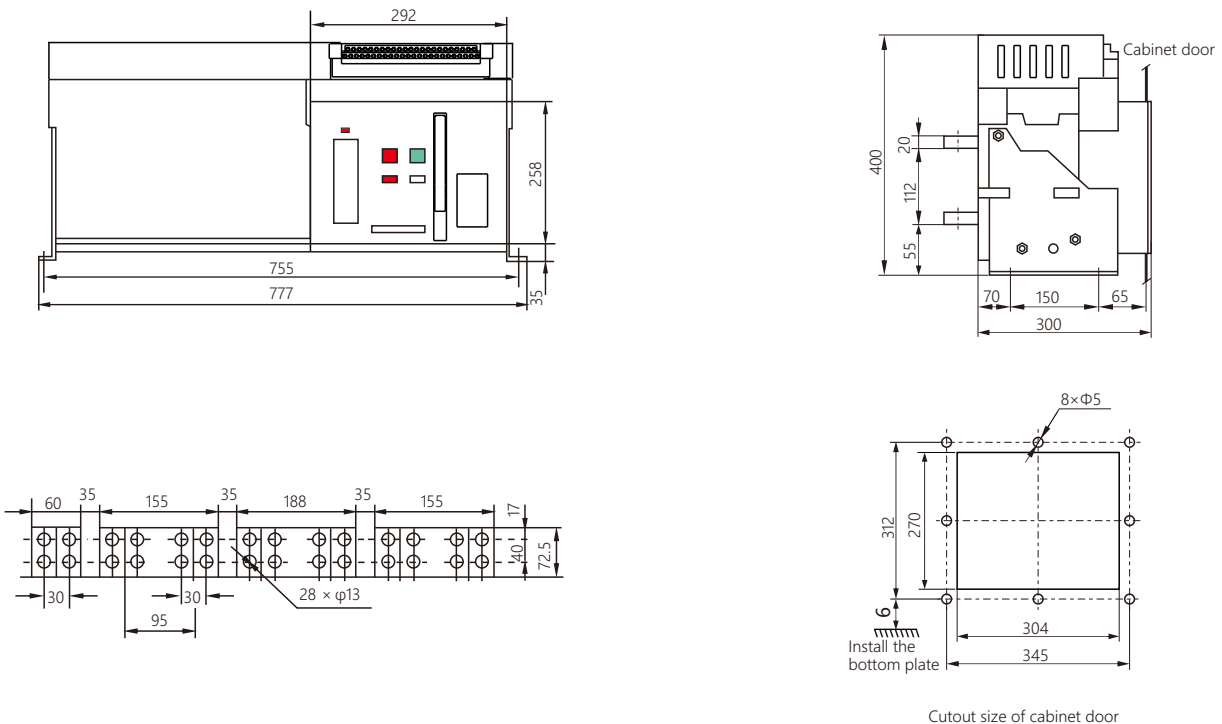

● NLW1-4000/4P Draw-out Circuit Breaker - Overall & Mounting Dimensions (mm).

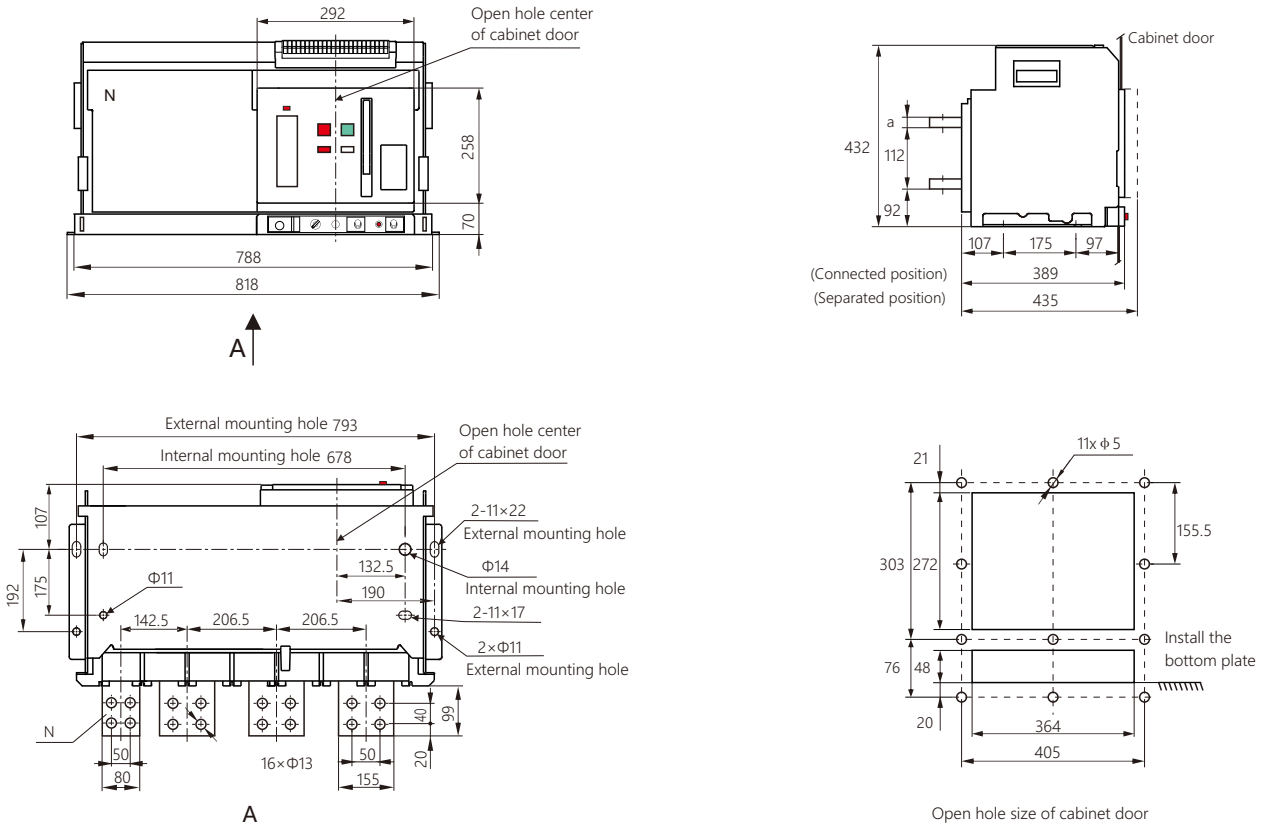

● NLW1-6300 Stationary Type Circuit Breaker - Profile & Installation Dimensions (mm)

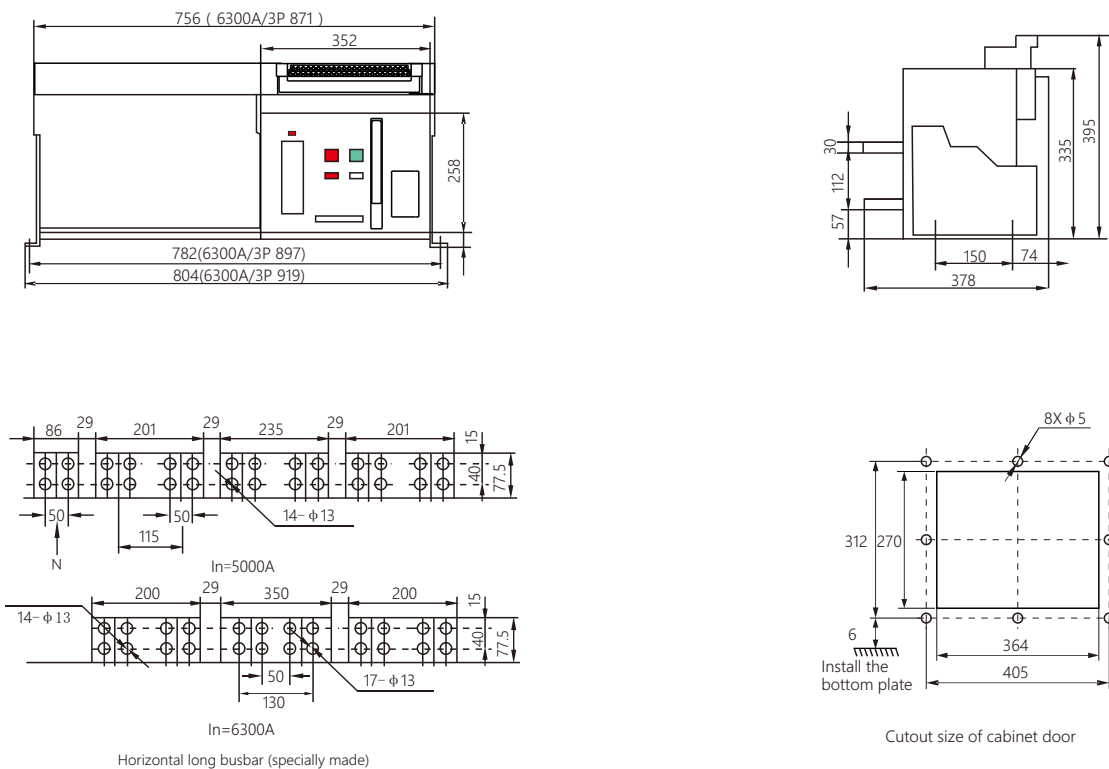

● NLW1-6300 Draw-out Circuit Breaker - Overall & Mounting Dimensions (mm).

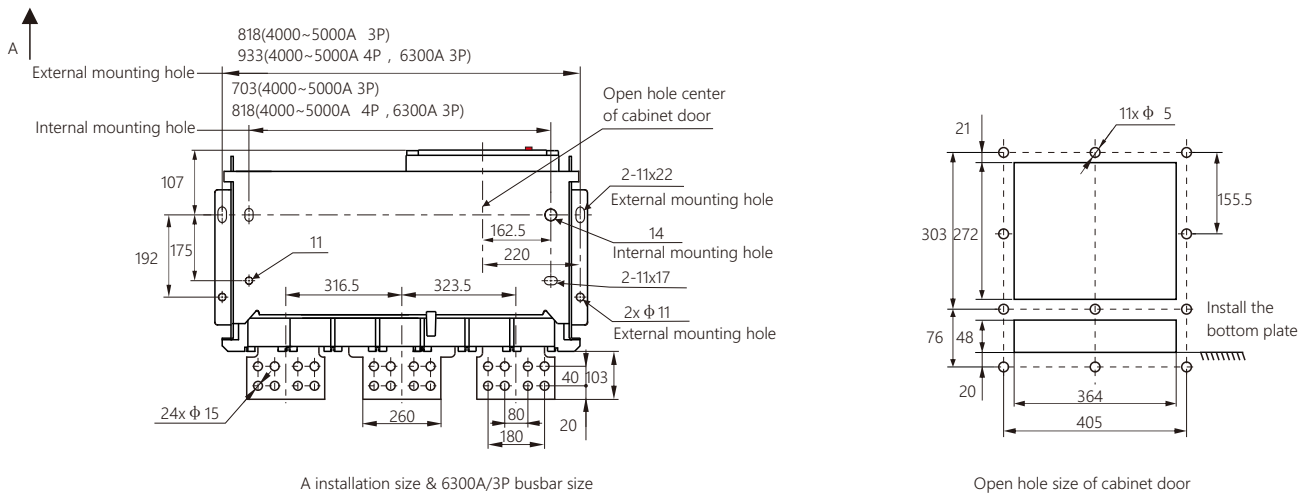
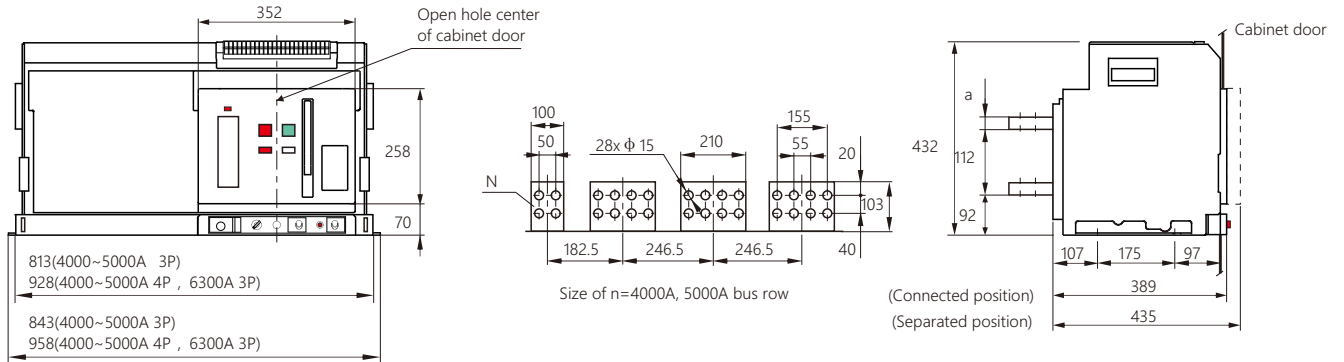

In	a
4000A	20
5000~6300A	30

Busbar thickness size

Intelligent Controller

- The description of panel display and function of the controller

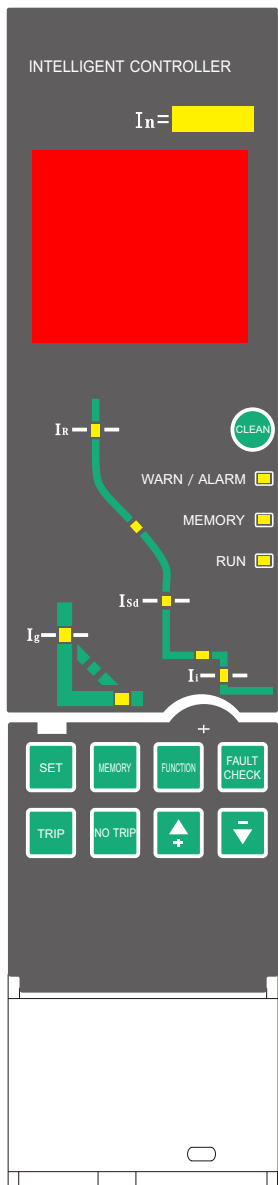







Information on the panel	Function declaration
In	Rated current of the controller
G	Current of ground or N phase (constant light refer to ground, flash refer to N phase)
L1	Current of phase A
L2	Current of phase B
L3	Current of phase C
MAX	Maximum phase current
A	Unit of current
kA	Unit of current
S	Unit of time (s)
test	Simulated tripping test
Ic1	Load monitoring No. 1
Ic2	Load monitoring No. 2
δ	Current imbalance protection
Ig	Ground protection
IR	Long time delay protection
I _{sd}	Short time delay protection
Ii	Instantaneous protection
WARN / ALARM	Fault alarm
MEMORY	Save information
RUN	In normal operation state
Button Function declaration	
CLEAN	Clear the fault display on screen and return to the run state
SET	Press the button, then click the button continuously to display all of parameters in sequence
MEMORY	Confirm to save when the parameters are set
FUNCTION	Auxiliary function
FAULT CHECK	Check the fault record
TRIP	Simulate tripping test
NO TRIP	Simulated non-tripping test
+	Adjust the set parameter value to be increased
-	Adjust the set parameter value to be decreased

- How to set the parameters of the intelligent controller

Use those four buttons on the controller panel:  ,  ,  ,  to set all the parameters of the controller.

The basic steps are described as follows:

- ① Click the button of "  " continuously to check all of parameters in sequence periodically. When a parameter is checked, the original set value of the parameter is displayed on the screen, and the corresponding indicator on the panel will be light on. If you do not need to change this parameter, go on clicking the button of "  " .
- ② If you need to change the original set parameter, click the button of "  " or "  " continuously. In the process of setting for current, in order to get the required set value quickly, the user can click the button of "function" to converse the mode of adjustment between fast adjustment code and fine adjustment code until the required value is achieved.
- ③ Press button of "  " to save the new set parameters. If no other parameters are required to be set, follow the step mentioned in ④ to exit the set. Otherwise, continue according to the step mentioned in ① .
- ④ Press the button of "  " to exit the setting state.

All the protection parameters of the controller should be set according to $I_{r1} < I_{r2} < I_{r3}$ strictly.

- Simulation test operation of the controller

Simulation characteristics test against grounded, long delay, short delay and instantaneous can be operated for the controller. Two kinds of test are available: tripping and non tripping. The first one needs to break the circuit breaker, - the second one does not break the circuit breaker. If faults such as overload or short circuit occurs during the test, the system will automatically terminate the test state and turn to the fault processing state.

● Panel Display and Function Description of Type 3H Controller



Panel Display	Function Description
In	Controller Rated Current Indication
LCM	LCD Display: Displays all controller parameters; main interface is current display.
Ig	Earth / Leakage Protection Indication
IR	Long Time Delay Indication
Is	Short Time Inverse Delay Indication
I _{sd}	Short Time Definite Delay Indication
Ii	Instantaneous Indication
Warn/Alarm	Protection active / self-diagnosis alarm: ON steady; Trip: fast flash.
Healthy	Normal operation: slow flash.
Bus	Normal communication: slow flash.
Button Function Description	
	Clear fault display after fault operation
	Enter Measurement menu: display real-time measured data; Left shift in password input
	Enter Settings: set operating parameters; Right shift in password input
	Enter Protection Settings: set all protection parameters
	View history records & system maintenance
	Increase value during parameter setting
	Decrease value during parameter setting
	Exit / return to upper menu / cancel current selection
	Confirm selection / Save modified parameters

Parameter Setting of NLW1-1600 & Above / Type 3H Controller

Various parameters of the controller can be set using the function keys on the controller panel: , , , , , . For example: setting the long-time overload protection. Current IR = 1000 A, to set it to 800 A and save, the procedure is as follows:

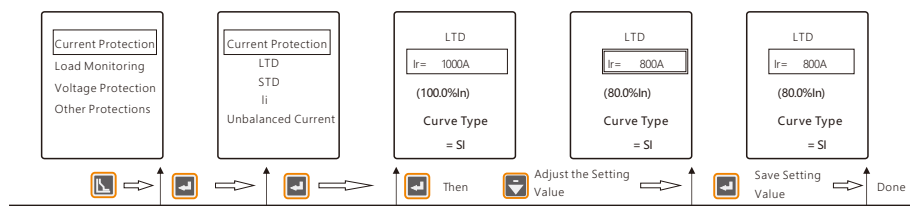

Simulated Trip Test of NLW1-1600 & Above / Type 3H Controller

The controller is equipped with a test trip function, used for on-site commissioning, periodic inspection or maintenance tripping tests, to verify the coordination between the controller and the circuit breaker.

Function and Characteristics of Accessories

- Mechanical interlock of the circuit breaker

a . Steel cable mechanical interlock: can make 2pcs or 3pcs horizontally or vertically mounted 3pole or 4pole circuit breaker be interlocked. (stationary type or drawer type)

b. Lever mechanical interlock: can make 2pcs or 3pcs vertically mounted 3pole or 4pole circuit breaker be interlocked. (stationary type or drawer type)

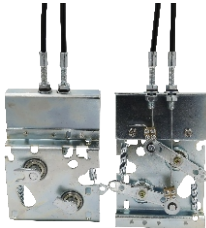

Steel cable mechanical interlock

Two circuit breakers interlocked by the steel cable interlock or lever interlock

Two power sources one load can only be integrated with one circuit breaker

Circuit diagram

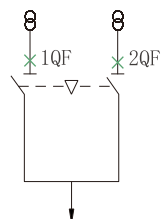

Possible operation mode

1QF	2QF
0	0
0	1
1	0

Three circuit breakers interlocked by the steel cable interlock or lever interlock

Three power sources one load can only be integrated with one circuit breaker

Circuit diagram

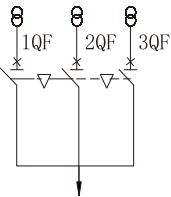

Possible operation mode

1QF	2QF	3QF
0	0	0
1	0	0
0	1	0
0	0	1

Two power sources two load can be integrated with two circuit breakers

Circuit diagram

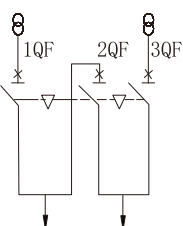

Possible operation mode

1QF	2QF	3QF
0	0	0
1	0	0
0	0	1
1	1	0
0	1	1
1	0	1

QF: circuit breaker



Lever type mechanical interlocking

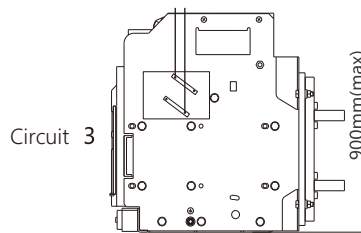
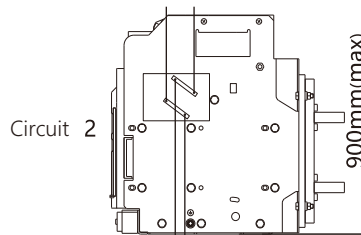
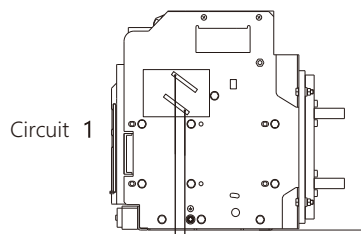
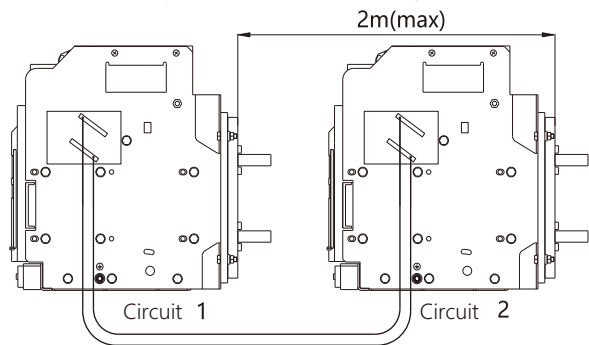

Three circuit breakers interlocked by lever mechanical interlock

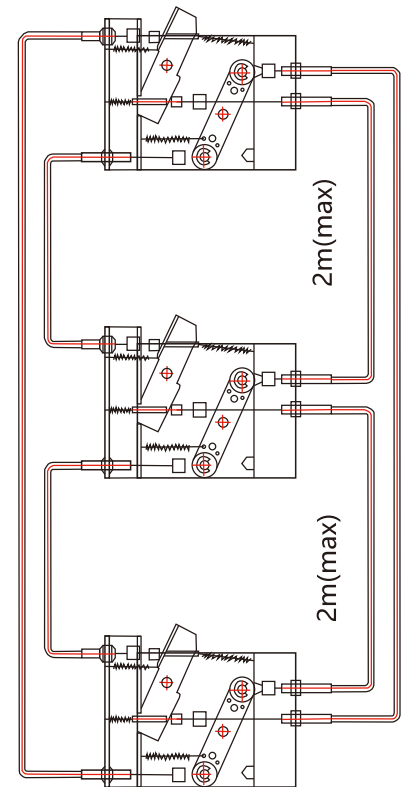

Three circuit breakers interlocked by steel cable mechanical interlock

Note: The transition arc at the bend of steel cable interlock shall not be less than R120mm, to ensure the cable is flexible.

- Residual current transformer

Residual current protection is suitable for leakage faults caused by insulation damage or leakage faults caused by human contact with leaking conductive parts. The leakage current has nothing to do with the rated current of the circuit breaker. Using the zero-sequence sampling method requires an additional zero-sequence current transformer. This kind of transformer has sampling accuracy and high sensitivity, and it is suitable for protection of smaller currents.

a. Characteristic parameters of the residual current transformer

Setting current (A)	$I_{\Delta n}$	0.5~30A+OFF (Grade difference is 0.1A, and OFF refers to exit)						Current error $\pm 10\%$					
	Performance characteristic	Action between (0.8~1.0) $I_{\Delta n}$						$\leq 0.8I_{\Delta n}$ no action; $> I_{\Delta n}$ Delay action of $n1.0$					
Delay time set T_g (s)		Instantaneous	0.06	0.08	0.17	0.25	0.33	0.42	0.5	0.58	0.67	0.75	0.83
The maximum break time of failure current (s)	$I_{\Delta n}$	0.02	0.36	0.5	1	1.5	2	2.5	3	3.5	4	4.5	5
	$2I_{\Delta n}$	0.02	0.18	0.25	0.5	0.75	1	1.25	1.5	1.75	2	2.25	2.5
	$5I_{\Delta n}/10I_{\Delta n}$	0.02	0.07	0.1	0.2	0.3	0.4	0.5	0.6	0.7	0.8	0.9	1

b. Profile dimension of residual current transformer (standard length of conductor for transformer is 2m)

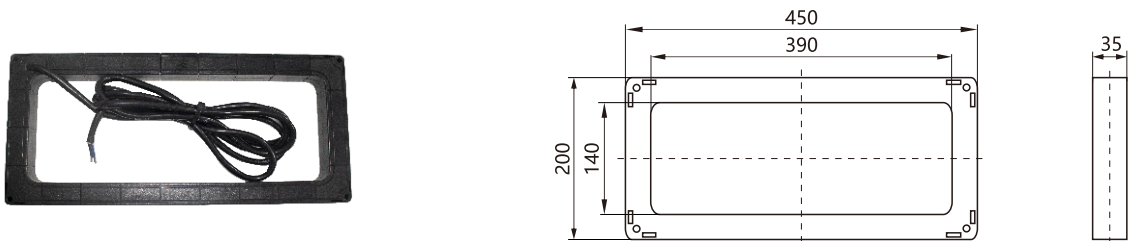

- External neutral wire transformer (3P + N).

When the controller is 3P + N, the installation dimension of the external neutral wire transformer is shown as below.(The length of external neutral wire transformer is 1.8m)

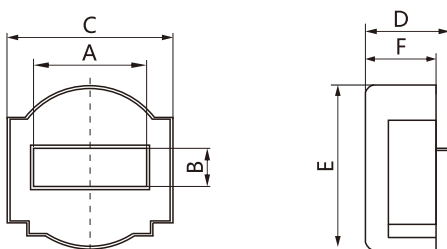

Frame grade	A	B	C	D	E	F
Frame I Transformer	60	20	90	44	90	37
Frame II & III transformer	90	30	108	44	105	37

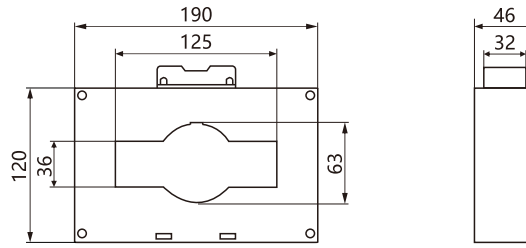
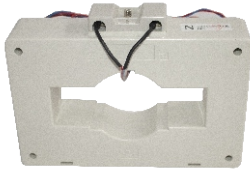

Dimension of customized neutral wire transformer

- Under voltage release

The power supply of under voltage release must be connected before the circuit breaker is switched on. When the power supply of circuit is under voltage or lost voltage, the circuit breaker is switched off to protect against the possible damage occurs to electrical device, to ensure reliability and security of circuit system. When the voltage of power supply resumes to 85% of U_e or even bigger, the circuit breaker will not be disconnected.

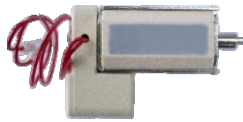

Under voltage release for 1600A circuit breaker



Under voltage release for circuit breaker not smaller than 2000A

Working voltage U_e	AC230V	AC400V
Action voltage range	(35 ~ 70)% U_e	
Reliable closing voltage range	(85 ~ 110)% U_e	
Cannot close the voltage range	$\leq 35\% U_e$	
Power dissipation	20VA	
Time-lapse time	Instant, 0. 5S, 1S, 3S, 5S, 10S, 20S	

- Shunt release

Using shunt release, the circuit breaker can be disconnected by remote mode at the specified supply voltage after the circuit breaker is switched on.

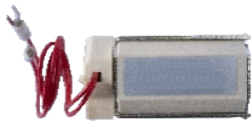

Shunt release for 1600A circuit breaker



Shunt release for circuit breaker not smaller than 2000A

Working voltage U_e	AC230V	AC230V	AC230V	AC230V
Action voltage range	(70 ~ 110)% U_e			
Start current	1.3A	0.7A	1.3A	2.5A
Response time	$\leq 30ms$			
Instant Power consumption	300VA		300VA	

- Closing electromagnet

After energy is stored in the circuit breaker, the circuit breaker can be switched on by remote mode at the specified supply voltage.



Under voltage release for 1600A circuit breaker



Under voltage release for circuit breaker not smaller than 2000A

Working voltage Ue	AC230V	AC400V	DC220V	DC110V
Action voltage range	(85 ~ 110)%Ue			
Start current	1.3A	0.7A	1.3A	2.5A
Response time	≤70ms			
Instant Power consumption	300VA		300VA	

- Electric motor for energy storage

It realizes the electric energy storage of the circuit breaker and re-energy storage operation automatically after the circuit breaker is switched on, so that the circuit breaker can be switched on again immediately once it is disconnected.

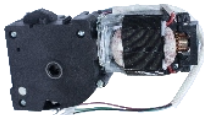

Type-1,600 for energy storage



Electric motor for energy storage of circuit breaker not smaller than 2000A

Working voltage Ue	AC230V	AC400V	DC220V	DC110V
Action voltage range	(85 ~ 110)%Ue			
Energy storage time	(5 ~ 7)s			
Type-1,600 power consumption	90VA		90W	
Type-2000 power consumption	85VA		85W	
Type 3200 / 4000 power consumption	110VA		110W	
Type-6300 power consumption	150VA		150W	

- Auxiliary contact

It can be used to monitor the state of breaker, such as connecting position signal light of breaker and disconnecting indicator. (default 4 groups of conversion contacts)



Auxiliary contact for 1600A circuit breaker



Auxiliary contacts for circuit breaker not smaller than 2000A

Working voltage Ue	AC230V	AC400V	DC220V	DC110V
Agreed heating current	6A			
Rated control capacity	300VA		60W	

- Door Frame

It is installed on the door of the power distribution cabinet to play a sealing role, and the protection level reaches Ip40. Two kinds of door frames are available: stationary type door frame and drawer type door frame



Stationary type door frame



Drawer type door frame

- Phase barrier

Installed between busbar to increase the insulation performance of the breaker.



Fixing strip



phase barrier (suitable for both stationary type and drawer type)

- Lock

When the toggle switch of the breaker is locked in the underneath position, the breaker cannot be switched on.

Note 1: When the key needs to be pulled out, the toggle switch must be hold first, then rotate counterclockwise to pull out the key;

Note 2: The following list of power supply methods is for reference only. Interlocking can be installed according to the actual power supply system on site, or the manufacturer can be consulted for negotiation.



a. One lock and one key:
one circuit breaker with one lock and one key

One power supply and one load interlock

Circuit diagram Possible operation mode

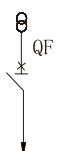

QF
0
1



b. Two locks and one key:
two circuit breakers are equipped with two identical locks and one key, and only one circuit breaker is allowed to be switched on

Two power supplies and one load interlock

Circuit diagram Possible operation mode

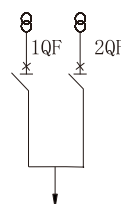

1QF	2QF
0	0
1	0
0	1

c. Three locks two keys: three circuit breakers with three identical locks and two keys, at most only allow two circuit breakers to be switched on

Two power supply and two load interlock

Circuit diagram Possible operation mode

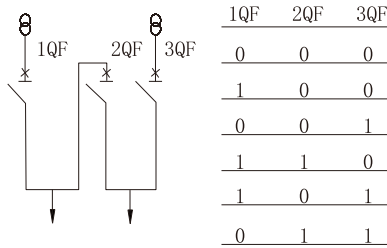

d. Three locks and one key: three circuit breakers with three identical locks and one key, allowing only one circuit breaker to be switched on

Three power supply one load interlock

Circuit diagram Possible operation mode

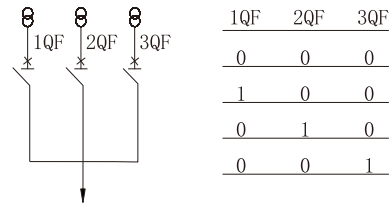

Installation

Before installation, check whether the specifications of the circuit breaker meet the requirements. Use a 500V megohmmeter to check the insulation resistance of the circuit breaker. When the ambient temperature is $20\pm 5^{\circ}\text{C}$ and the relative humidity 50%~70%, the insulation resistance of the circuit breaker should not be less than 10MQ.

Otherwise, it should be dried and used only after the insulation resistance reaches the requirements.

During installation, the base should be in a horizontal position and fixed by M10 screws. At the same time, the circuit breaker should be reliably protected and grounded. There should be an obvious grounding mark on the grounding point. Fixed circuit breakers should be strictly arranged in the safety zone.

After the circuit breaker is installed and connected according to the relevant wiring diagram, a series of operational tests should be carried out before the main circuit is energized (the indicator on the drawer base of the drawer-type circuit breaker is in the test position):

- Check whether the under voltage, shunt release, closing electromagnet, and electric operating voltage are consistent (the circuit breaker can operated only after the under voltage release is on)
- After pulling the handle on the panel up and down seven times, the screen displays "Energy Storage" and a "click" sound is heard, which means the enegy storage is completed. Press the "1" button or connect the electromagnet to r energize the circuit breaker. Pull the handle to store energy again.
- Power on the motor until the screen displays "Energy Storage", and with a "click" sound, the energy storage is completed, the motor automatically cuts off power, press the "1" button or connect the electromagnet to energize the circuit breaker reliably.
- After the circuit breaker is switched on, the circuit breaker should be able to be disconnected regardless of the tripping test executed by under voltage release, shunt release, the "0" button on the panel or the intelligent release.

Maintenance (at least once every six months)

All friction and rotating parts should be lubricated regularly. Check whether the bolts at the connections between the circuit breaker and the busbar are tightened well and contact is good or not.

The dust accumulation status between the circuit breaker body and the insulation of the drawer base should be checked and cleaned regularly. Also check if the secondary circuit terminal connection of the circuit breaker is reliable. Check whether the intelligent controller of the circuit breaker displays normally, the protection characteristic setting value of the intelligent controller is correct, and the opening and closing indication of the circuit breaker is correct or not.

Overhaul (at least once a year)

Check whether all parts of the circuit breaker are complete and clean, such as the shell, chassis and other insulating parts. Check whether the base of the circuit breaker (connected to the base plate) is firm and no vibration during operation.



The manual opening and closing mechanism should be flexible and free of jamming. The secondary circuit auxiliary switch conversion should be reliable and correct. When the secondary circuit is energized, the shunt release, the operation of the magnet and under voltage release should comply with the technical regulations of the products, and the electric operating mechanism should operate normally.

The contact system of the arc extinguishing chamber and the contact fingers should be complete, their position should be accurate. The silver plating layer should be intact, the arc extinguishing chamber should be cleaned (note that the mechanism must not be switched on when cleaning the arc extinguishing chamber). The circuit breaker and the connection busbar should be connected reliably and the bolts should be tightened.

Check whether the surface of the contact piece connecting the main body and the drawer base is clean and tidy. It should be cleaned to remove dust and oxides on the surface to ensure reliable connection.

Troubleshooting and Solutions

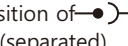
Problems	Probable causes	Solutions
Circuit breaker tripping (fault indicator on)	Overload tripping (Long delay indicator is on)	Check the tripping current value and operation time set in the intelligent controller, find out fault and eliminate it. Press the reset button to switch on the circuit breaker again. If the actual running current does not match the set long delay action current value, please modify the Long delay action current setting value according to the actual running current to achieve appropriate matching protection.
	Short circuit tripping (Short delay or the instantaneous indicator is on)	Check the tripping current value and operation time set in the intelligent controller, find out and eliminate the fault. Press the reset button to switch on the circuit breaker again.
	Groundfault tripping (Ground fault indicator is on)	Check the tripping current value and operation time set in the intelligent controller, find out and eliminate the fault. Press the reset button to switch on the circuit breaker again.
	Under voltage release tripping	1) Check if the power supply voltage of under voltage release must be not smaller than 85% Ue; 2) Check whether the under voltage release and the control unit are out of order.
	Mechanical interlocked device action	Check the operating state of 2pcs of mechanical interlocked circuit breakers.
Can't be switched on	Under voltage release doesn't actuate	1) Whether under voltage release is powered on 2) Check whether the power supply voltage is lower than 85% Ue; 3) Check whether the under voltage release is burned out. If it is, replace it.
	The reset button doesn't reset	Press the reset button to restart the circuit breaker.
	Drawer type circuit breaker has not been shaken in place	Shake the drawer type breaker in place (you should hear two "click" sounds)
	Poor contact happens to the secondary bop of drawer type circuit breaker	Check the secondary loop contact situation and eliminate it.
	Energy has not been stored in the circuit breaker	1) Check whether the Electric motor control power supply is connected and must be $\geq 85\%U_s$; 2) Check if the fault happens to electric motor energy storage mechanism
	Mechanical interlock acts while the circuit breaker is locked	Check whether the mechanical interlocking working state of the two circuit breakers is normal.
	Problem occurs to the closing electromagnet	1) Check whether the closing electromagnet is connected to the power supply well and the voltage should be $\geq 85\%U_s$; 2) If the closing electromagnet is fault and can not realize actuation, replace it.
	Wiring error in shunt release	Shunt release should be connected with NO contact of pushbutton switch.

Circuit breaker tripping after switched on	<ol style="list-style-type: none"> 1) Tripping immediately 2) Tripping with delay 	<ol style="list-style-type: none"> 1) Check the breaking current value and action time in the intelligent controller; 2) If it is short circuit, please check and eliminate the hitch; 3) If it is overload, please check and eliminate the hitch; 4) Check whether the shunt release is connected with pushbutton switch wrongly or not, then press the reset button to switch on the circuit breaker again.
Circuit breaker can't be disconnected	<ol style="list-style-type: none"> 1) Can't be switched off by electric drive 2) Can't be switched off manually 	<ol style="list-style-type: none"> 1) Check whether the shunt release circuit is well connected. Check if failure happen to shunt release. If fault is confirmed, replace it; 2) Check the operating mechanism, whether there is mechanical failure.
Circuit breaker can't store energy	<ol style="list-style-type: none"> 1) Can't store energy manually 2) Energy storage can not fulfilled by electric drive 	<ol style="list-style-type: none"> 1) Check the operating mechanism, whether there is mechanical failure; 2) Check whether the operation handle is stuck; 3) Check whether the control power supply voltage of the electric energy storage device is $\geq 85\%U_s$; whether there is any problem with the circuit connection; 4) Check if something wrong with electric motor
Drawer type circuit breaker cannot withdraw in the position of  (separated)	<ol style="list-style-type: none"> 1) The handle is not pulled out 2) The circuit breaker has not been reached to the position of "separated" fully. 	<ol style="list-style-type: none"> 1) Pull out the handle; 2) Shake the circuit breaker completely to the position of  (separated); 3) Check whether any foreign object is stuck in the drawer.
Drawer type circuit breaker cannot be rolled to the Connection position	A foreign object falls into the drawer base and jam the advance mechanism or the pushing mechanism. Damage might occur to the gear.	<ol style="list-style-type: none"> 1) Check whether rack or gear are stuck by foreign object or not; 2) Check whether the drawer partition plate falls off; 3) The rated current of the frame level of the circuit breaker does not correspond to that of the drawer base.
No display on the screen of intelligent controller	<ol style="list-style-type: none"> 1) The intelligent controller has not been connected to the power supply. 2) Input terminal and voltage of auxiliary power supply is not in order 3) Fault happens to the intelligent controller 	<ol style="list-style-type: none"> 1) Check whether the intelligent controller is well connected with control power. 2) Disconnect the control power of the intelligent controller, and connect the power again. If failure still exists, the controller needs to be replaced.

Attention While Odering

Model		NLW1-1600	NLW1-2000	NLW1-3200	NLW1-4000/4P	NLW1-6300	
Rated voltage		<input type="checkbox"/> AC400V <input type="checkbox"/> AC690V					
Type		<input type="checkbox"/> Drawer type <input type="checkbox"/> Stationary type					
Rated Current In (A)		<input type="checkbox"/> 200 <input type="checkbox"/> 400 <input type="checkbox"/> 630 <input type="checkbox"/> 800 <input type="checkbox"/> 1000 <input type="checkbox"/> 1250 <input type="checkbox"/> 1600	<input type="checkbox"/> 400 <input type="checkbox"/> 630 <input type="checkbox"/> 800 <input type="checkbox"/> 1000 <input type="checkbox"/> 1250 <input type="checkbox"/> 1600 <input type="checkbox"/> 2000	<input type="checkbox"/> 2000 <input type="checkbox"/> 2500 <input type="checkbox"/> 2900 <input type="checkbox"/> 3200 <input type="checkbox"/> 4000(expansion)	<input type="checkbox"/> 3600 <input type="checkbox"/> 4000	<input type="checkbox"/> 4000 <input type="checkbox"/> 5000 <input type="checkbox"/> 6300	
Number of pole		<input type="checkbox"/> 3 poles <input type="checkbox"/> 4 poles					
Intelligent controller		Control voltage		<input type="checkbox"/> AC230V <input type="checkbox"/> AC400V <input type="checkbox"/> DC220V <input type="checkbox"/> DC110V			
		Basic function		Auxiliary function		Optional function	
		Overload Long delay, protection, short circuit Short delay protection, short circuit Instant, protection, grounding protection		1. Ammmeter function 2. Self-diagnosis function 3. Complete the function 4. Test function 5. Display function		<input type="checkbox"/> Voltage display <input type="checkbox"/> Frequency display <input type="checkbox"/> Power factor display <input type="checkbox"/> Active power display <input type="checkbox"/> Load monitoring <input type="checkbox"/> MCR function Note: The cost of the optional function is offered additionally	
Electrical accessories	Under voltage release (Optional)	Control voltage		<input type="checkbox"/> AC230V <input type="checkbox"/> AC400V			
	Shunt release	<input type="checkbox"/> Under voltage Instant tripping device <input type="checkbox"/> Under voltage delay tripping device		Delay under voltage value at zero <input type="checkbox"/> 0.5s <input type="checkbox"/> 1s <input type="checkbox"/> 3s <input type="checkbox"/> 5s <input type="checkbox"/> 10s <input type="checkbox"/> 20s			
	Closing electromagnet	<input type="checkbox"/> AC230V <input type="checkbox"/> AC400V		<input type="checkbox"/> DC220V <input type="checkbox"/> DC110V			
	Electric motor for energy storage	<input type="checkbox"/> AC230V <input type="checkbox"/> AC400V		<input type="checkbox"/> DC220V <input type="checkbox"/> DC110V			
	Auxilia contact	<input type="checkbox"/> 4 groups conversion (default) <input type="checkbox"/> 5 groups conversion		<input type="checkbox"/> 4NO+4NC <input type="checkbox"/> 6NO+6NC			
	Mechanical interlock	Two circuit breakers <input type="checkbox"/> Steel cable Inter lock <input type="checkbox"/> Lever Interlock (Upper and Lower Interlock)		Three circuit breakers <input type="checkbox"/> Steel cable Inter lock <input type="checkbox"/> Lever Interlock (Upper and Lower Interlock) Note: There are two in one or one in two			
Lock	<input type="checkbox"/> One lock, one key <input type="checkbox"/> Two locks one key		<input type="checkbox"/> Three locks one key <input type="checkbox"/> Three locks and two keys <input type="checkbox"/> special				
Other functions	<input type="checkbox"/> External residual current transformer		<input type="checkbox"/> External neutral wire transformer (3P + N)				
Dual power controller	<input type="checkbox"/> Double standby self-cast controller		<input type="checkbox"/> Parent joint standby self-cast controller				
Mode of connection	<input type="checkbox"/> Vertical eiring (with L-type vertical busbar)		Note:conventional products are horizontal wiring				
Special accessories							

Remarks

- a. Frame current, rated current and auxiliary control voltage must be specified while ordering.
- b. Generally products are supplied with shunt release, closing electromagnet, electric motor, intelligent controller, 4 groups of conversion contacts, horizontal wiring of main loop, alternate partition, door frame, installation bolt, and instruction manual as well.
- c. The cost of optional functions, special accessories, customized accessories involved in the above table shall be calculated additionally. Please contact the local distributor if there is any special requirement.